





1958

CORVETTE

SPECIFICATIONS

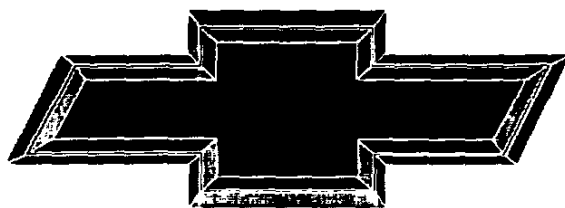
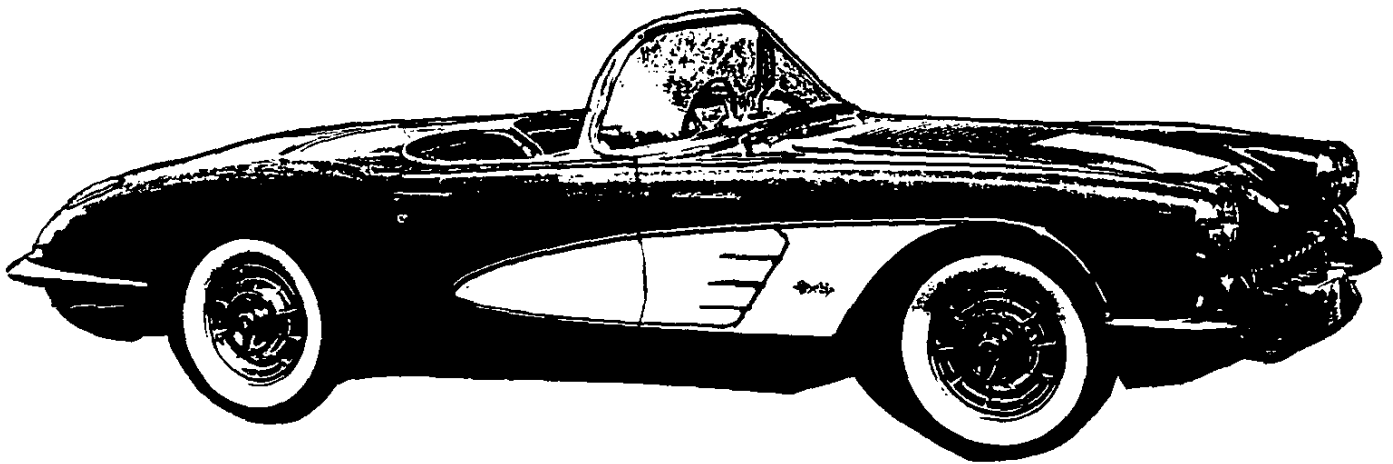

GENUINE CHEVROLET™



→

→



1958 CORVETTE

Production: 9,168 convertibles

1958 NUMBERS

Vehicle: J58S100001 through J58S109168

Suffix: CQ: 283ci, 230hp, mt CU: 283ci, 270hp, mt
CR: 283ci, 250hp, mt DG: 283ci, 230hp, at
CS: 283ci, 290hp, mt DH: 283ci, 250hp, at
CT: 283ci, 245hp, mt DJ: 283ci, 245hp, at

Block: 3737739 or 3756519: All

Head: 3748770: All (sh)

Carburetor: Carter 2613S #3741089: 283ci, 270hp, fc
Carter 2614S #3741090: 283ci, 270hp, rc
Carter 2626S #3744002: 283ci, 245hp, fc
Carter 2627S #3744004: 283ci, 245hp, rc
Carter 2669S #3746384: 283ci, 230hp

Fuel Injection: Rochester 7014800: 283ci, 250hp
Rochester 7014800R: 283ci, 290hp, ep
Rochester 7014900: 283ci, 250hp
Rochester 7014900R: 283ci, 290hp
Rochester 7014960: 283ci, 290hp
Rochester 7017200: 283ci, 250hp, lp

Distributor: 1110890: 283ci, 230hp 1110914: 283ci, 290hp
1110891: 283ci, 245hp, 270hp 1110915: 283ci, 250hp
1110908: 283ci, 290hp, ep

Generator: 1102043: 283ci, 230hp, 245hp, 250hp, 270hp
1102059: 283ci, 290hp

Ending Vehicle: Oct 57: 100486 Feb 58: 104789 Jun 58: 108192
Nov 57: 101443 Mar 58: 105779 Jul 58: 108840
Dec 57: 102511 Apr 58: 106544 Aug 58: 109168
Jan 58: 103677 May 58: 107489

Abbreviations: at=automatic transmission, ci=cubic inch, fc=front carburetor, fd=first design, ep=early production, hp=horsepower, lp=late production, mt=manual transmission, rc=rear carburetor, sd=second design, sh=staggered valve cover holes.

1958 FACTS

- Extensive redesign for 1958 included new body panels, new instrument panel and new upholstery. External distinguishing features included dual headlights, a Corvette first, non-functional louvers on the hood, and twin chrome trunk spears.
- The interior for 1958 had a large 160-mph speedometer flanked by secondary instruments. The tachometer was relocated from its previous central instrument panel location to just above the steering column. A passenger grab bar was built into the passenger side. A central console was included. Door panels were a two-piece design.
- Seat belts were factory-installed for the first time in 1958 Corvettes. Previously, they had been dealer-installed accessories. However, seat belt anchors were installed in 1956-57 at the factory.
- Correct 1958 valve covers had staggered hold-down holes and attach with Phillips head screws. The base 283ci, 230hp engine had painted steel covers. All optional engines had seven-fin cast alloy valve covers.
- Low-loop rayon pile carpeting was factory-installed in 1958 Corvettes.
- Carbureted engines were equipped with glass fuel filter bowls.



1

2



1958 OPTIONS

CODE	DESCRIPTION	QTY	RETAIL \$
867	Base Corvette Convertible	9,168	\$3,591.00
101	Heater	8,014	96.85
102	AM Radio, signal seeking	6,142	144.45
107	Parking Brake Alarm	2,883	5.40
108	Courtesy Light	4,600	6.50
109	Windshield Washers	3,834	16.15
276	Wheels, 15x5.5 (5)	404	0.00
290	Whitewall Tires, 6.70x15	7,428	31.55
313	Powerglide Automatic Transmission	2,057	188.30
419	Auxiliary Hardtop	5,607	215.20
426	Power Windows	649	59.20
440	Two-Tone Exterior Paint	3,422	16.15
469	283ci, 245hp Engine (2x4 carburetors)	2,436	150.65
469C	283ci, 270hp Engine (2x4 carburetors)	978	182.95
473	Power Operated Folding Top	1,090	139.90
579	283ci, 250hp Engine (fuel injection)	504	484.20
579D	283ci, 290hp Engine (fuel injection)	1,007	484.20
677	Positraction Rear Axle, 3.70:1	1,123	48.45
678	Positraction Rear Axle, 4.11:1	2,518	48.45
679	Positraction Rear Axle, 4.56:1	370	48.45
684	Heavy Duty Brakes and Suspension	144	780.10
685	4-Speed Manual Transmission	3,764	215.20

- A 283ci, 230hp engine, 3-speed manual transmission, vinyl interior trim, and a soft top were included in the base price.
- RPO 684 included special front and rear springs and shock absorbers, heavier front stabilizer bar, quick steering adaptor, metallic brakes, finned brake drums, fresh air ducting to rear brakes and front brake air deflectors (except very early models). Positraction axle, manual transmission and RPO 579D were required.
- RPO 276 included hubcaps (small) in lieu of standard wheel discs.
- The 5,607 RPO-419 (auxiliary hardtop) quantity included 2,215 in lieu of soft tops at no charge.
- The 504 RPO-579 (250hp engine) quantity was split 400 with manual transmissions, 104 with Powerglide automatic transmissions.
- The 2,436 RPO-469 (245hp engine) quantity was split 1,897 with manual transmission, 539 with Powerglide automatic transmissions.
- RPOs 677, 678 and 679 (Positraction) required manual transmission.

1958 COLORS

EXTERIOR	QTY	SOFT TOP	WHEELS	INTERIOR
Charcoal	1,631	Bk-W	Silver	Bg-C-R
Snowcrest White	2,477	Bk-W-Bg	Silver	Bg-C-R
Silver Blue	2,006	Bg-W	Silver	Bg-C
Regal Turquoise	510	Bk-W	Silver	C
Panama Yellow	455	Bk-W	Silver	C
Signet Red	1,399	Bk-W	Silver	C-R
Black	493	Bk-W	Silver	C-R
Silver	193	Bk-W	Silver	C-R

- Suggested interiors shown. Other combinations were possible.
- Interiors and exteriors were not coded to individual cars. In 1958, four Corvettes were painted a non-standard color, combination, or primer.
- The 3,422 quantity for code 440 two-tone paint (contrasting cove) was split 757 Silver Blue/silver; 756 Signet Red/white; 729 Charcoal/silver; 499 Snowcrest White/silver; 252 Regal Turquoise/white; 190 Panama Yellow/white; 199 Black/silver; 36 Silver/black; 4 uncertain.
- The Charcoal exterior color is believed to have been replaced by Black somewhere past the mid-point of 1958 production.
- The wheels of RPO 276 may have been painted black instead of silver.

Abbreviations: Bg=Blue-Gray, Bk=Black, C=Charcoal, R=Red, W=White.



1



The Corvette Black Book

1953-1993

October 1992

Published by
Michael Bruce Associates, Inc.
 Michael Antonick, President
 Post Office Box 396
 Powell, Ohio 43065



CONTENTS

Glossary	4	1981 Corvette	76
Instructions	5	1982 Corvette	78
Statistics	12	1984 Corvette	80
Chronology	14	1985 Corvette	82
1953 Corvette	20	1986 Corvette	84
1954 Corvette	22	1987 Corvette	86
1955 Corvette	24	1988 Corvette	88
1956 Corvette	26	1989 Corvette	90
1957 Corvette	28	1990 Corvette	92
1958 Corvette	30	1991 Corvette	94
1959 Corvette	32	1992 Corvette	96
1960 Corvette	34	1993 Corvette	98
1961 Corvette	36	Notes	100
1962 Corvette	38	Photos/Specs	104
1963 Corvette	40	Literature	124
1964 Corvette	42	Coupons	127

© Michael Bruce Associates, Inc.: 1978, 1980, 1983, 1985, 1988, 1991, 1992. All rights reserved under Pan American and Universal Copyright Conventions by Michael Bruce Associates, Inc. Reproduction without permission is prohibited. Because of the possibility of errors, exceptions, or other reasons for inaccuracy, the publisher and author disclaim responsibility for the accuracy of any or all information presented in this publication.

Michael Bruce Associates, Inc. acknowledges with appreciation the following enthusiasts who contributed their expertise to this and previous editions of the Corvette Black Book: Roland Adams, Dan Mdririga, John Angwert, Pat Baker, Jane Barthelme, Michele Boling, Kent Brooks, Barry Brown, David Burroughs, Steve Dangrenmond, Dr. M. F. Dobbs, Bob Eckles, the late Sam Foltz, John Hibbert, Mike Hunt, Alan Kaplan, Paul Kleihen, Gary Komner, Ralph Kramer and staff, Jim Krugroff, Gary Lusk, Bill Locke, Bob Logiewski, Bob McDorman, Chip Miller, Bill Mock, Brian Pearce, John Poloney, Bill Rhodes, Jeffrey Smith, Mark & Dixie Smith, Lou Vitale, Jerry Wadsworth, Jerry Watchers and Don Williams. Thanks also to Callaway Engineering, to Mercury-Marine, and to the Chevrolet Motor Division of General Motors Corporation.

Notice: The Corvette Black Book and its publisher, Michael Bruce Associates, Inc. have no relationship or connection whatever with Hearst Business Media Corporation, its parent or affiliated corporations, or the Black Book published by National Auto Research Division of Hearst Business Media Corporation.

Michael Bruce Associates, Inc. and the Corvette Black Book are not associated with or sponsored by General Motors or its Chevrolet Motor Division. Cover: Photo and design by Mike Antonick. 1963 Corvette owned by Bill Munzer; restored by Bill Munzer and Don Williams. Printed and bound in the United States of America.

ISBN: 0-933534-35-3



BLACK BOOK ORDER FORM

Send _____ copies of the

Corvette Black Book 1953-1993

@ \$11.95 each \$ _____
 Ohio residents add .72 sales tax _____
 Postage/hard shipping container 3.00
 Check or money order enclosed \$ _____

Name _____
 Street _____
 City _____ State _____ Zip _____

Mail Order To: Michael Bruce Associates, Inc.
 Post Office Box 396
 Powell, Ohio 43065

BLACK BOOK ORDER FORM

Send _____ copies of the

Corvette Black Book 1953-1993

@ \$11.95 each \$ _____
 Ohio residents add .72 sales tax _____
 Postage/hard shipping container 3.00
 Check or money order enclosed \$ _____

Name _____
 Street _____
 City _____ State _____ Zip _____

Mail Order To: Michael Bruce Associates, Inc.
 Post Office Box 396
 Powell, Ohio 43065



1



ORIGINAL COPY

CORVETTE SUPPLEMENT

CORVETTE DIMENSIONAL

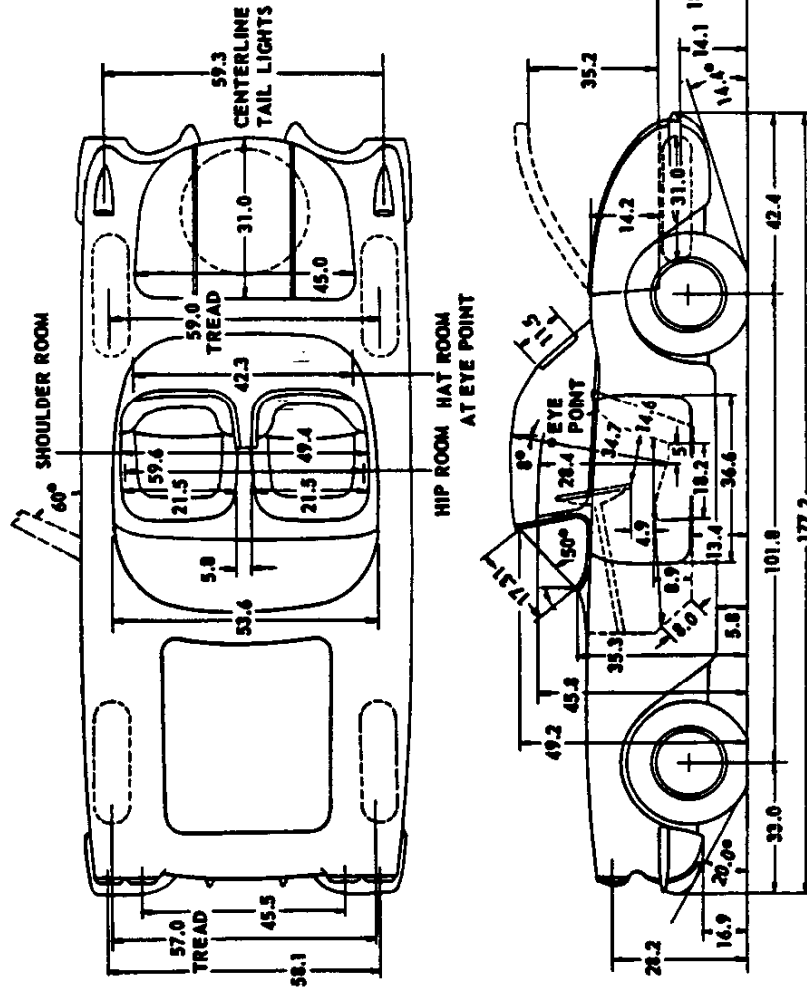

DRIVER SEAT ADJUSTMENT 4.4 SEAT DIMENSIONS SHOWN ARE MEASURED 15" FROM CENTER LINE OF CAR WITH SEAT IN REAR POSITION.

HARDTOP WRAP-AROUND REAR WINDOW WIDTH 47.90

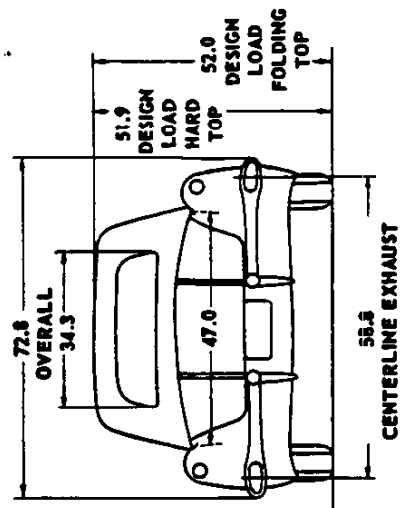

CORVETTE CONVERTIBLE (MODEL 867)

EXTERIOR-INTERIOR COLOR COMBINATIONS

Body Color and Wheels*	Body Cove Area (Optional)	Folding Top	Interior Trim Instrument panel and cluster, steering wheel and hub, direction signal housing, heater cover panel, radio grille screen, defroster escutcheon, cockpit housing divider.		
			Charcoal	Blue Gray	Red
Charcoal	Inca Silver	Black or White	Charcoal	Blue-Gray	Red
Snowcrest White		Black White or Blue-Gray	Charcoal	Blue-Gray	Red
Silver Blue		White or Blue-Gray	Charcoal	Blue-Gray	
Regal Turquoise	Snowcrest White	Black or White	Charcoal		
Panama Yellow		Black or White	Charcoal		
Signet Red		Black or White	Charcoal		Red

* - Includes hardtop when used.

INTERIOR COLORS AND FABRICS

Item		Material	Trim Combination		
			Charcoal	Blue-Gray	Red
Seats	Cushion	Chatham Grain Vinyl	Charcoal	Blue-Gray	Red
	Backrest				
	Cushion Bolster				
	Backrest Bolster				
Headlining **					
Sidewalls	Upper Panel				
	Lower Panel	Textured Metal			
	Divider Molding and Armrest End Insert	Metal		Bright	
	Armrest	Chatham Grain Vinyl			
	Scuff Pad	Paint	Charcoal	Blue-Gray	Red
	Cowl Side Kick Panels	Chatham Grain Vinyl			
Step Plate		Metal		Bright	
Floor Covering		Carpet	Charcoal	Blue-Gray	Red
Top Storage Well		Paint			
Reflectors		Plastic		Red	
Rear Compartment	Mat	Rubber	Charcoal	Blue-Gray	Red
	Trim Board	Composition Board			

** - Hardtop only

GENERAL DATA - CHASSIS

VEHICLE SERIAL NUMBER

Series designation

E ----- 8 cylinder engine
S ----- St Louis

ENGINE IDENTIFICATION *

Type & designation

With 3-speed transmission ----- CQ
With 3-spd. trans. two 4 bbl. carb & spec. cam. -- CU
With 3-speed trans and two 4 bbl. carb. ----- CT
With 3-spd. trans., Fuel Inj. & spec. camshaft --- CS
With 3-speed trans. & Fuel Injection ----- CR
With two 4 bbl. carb. and Powerglide ----- DJ
With Fuel Injection and Powerglide ----- DH
With Powerglide ----- DG

REAR AXLE IDENTIFICATION

Type and designation

With 3-spd. trans. (3.70:1 ratio) -----AH
With Powerglide (3.55:1 ratio) -----AE
Limited slip differential (3.70:1 ratio) -----AN
Limited slip differential (4.11:1 ratio) -----AP
Limited slip differential (4.56:1 ratio) -----AQ
Lim. slip diff. HD sus & brake(3.70:1 ratio) -----AS
Lim. slip diff. HD sus & brake(4.11:1 ratio) -----AT
Lim. slip diff. HD sus & brake(4.56:1 ratio) -----AU

DIMENSIONS

Wheelbase ----- 101.85
Length (overall) ----- 177.20
Width (overall) ----- 72.8
Height (ground to top of windshield at centerline) . . .
----- 49.20
Height (overall loaded)
Folding top ----- 52.0
Hard top ----- 51.9
Angle of approach ----- 20.0°
Angle of departure ----- 14°40'
Treads:
Front ----- 57.00
Rear ----- 59.00

VEHICLE WEIGHTS *

Powerglide transmission
Shipping ----- 2889 lb.
Curb ----- 3034 lb.
Loaded ----- 3334 lb.
3-speed transmission
Shipping ----- 2781 lb.
Curb ----- 2926 lb.
Loaded ----- 3226 lb.
Optional hard top ----- 55 lb.

* - Curb weight: This is the weight of the empty vehicle ready to drive. It is the shipping weight plus the weight of gasoline (107) and water (38 lb.)
For definition of shipping weight see page P-5

BODY GLASS

Windshield ----- Laminated safety plate
Side doors ----- Laminated safety plate
Canvas top,
Rear window ----- Vinyl plastic
Hard Top,
Rear window ----- Acrylic plastic (plexiglass)
Rear quarter window --- Acrylic plastic (plexiglass)

FRONT WHEEL ALIGNMENT (Service data)

Camber ----- 0°-1°
Caster ----- 2°15'
King pin inclination ----- 3°30'-4°-30'
Toe in ----- 0-.125

FRAME

Make & type ----- Own, box girder with "X" member
Maximum overall length ----- 139.28
Maximum overall width (over side members)--- 43.24
Material ----- Hot rolled steel
Material yield point ----- 33,000 lb./sq.in.
Material elongation ----- 25% minimum in 2 in.
Side member section modulus (inches cubed)--- 1.677
Moment of inertia (in⁴)----- 4.930
Construction:
Side members ----- Box section, each composed of two full length channel sections welded together.
Front suspension cross member ----- Flanged semi-tubular section with flat steel bottom plate welded on.
Rear shock absorber upper mounting cross member. ----- Inverted channel section.
Rear cross member ----- Box section composed of a flanged channel section and a welded on bottom plate.
Center "X" member ----- Composed of I-beam sections attached to side members at the end of each leg of the "X". Also attached to the forward section of side members by long angular braces from the front legs of the "X".
Body mounting points ----- 10

KING PINS

Diameter ----- .8660-.8665
Bushings
Inside diameter ----- .867-.868
Length ----- 1.312

STEERING KNUCKLE

Type ----- Reverse Elliot
Spindle diameter:
At inner bearing ----- 1.2801-1.2806
At outer bearing ----- .7490-.7495

SPRING MOUNTING

Type ----- Parallel 47.24 between centers
Front eye bolt diameter ----- .498-.502
Shackle mounting ----- Outrigger type
Shackle type ----- Rubber bushed
Shackle pin O.D. ----- .620-.625

GENERAL DATA - CHASSIS-Continued

Front Springs:

Make and type ----- Own, coil
 Material and gauge----- Chrome alloy steel .547-.553
 Number of coils ----- Total 9.75; active 7.94
 Diameter ----- Outside 4.30; pitch 3.752
 Height ----- Free 13.45; working 9.62@ 1145 lb.
 Height under curb weight ----- 9.72
 Capacity at ground ----- 800 lb.
 Deflection rate
 At spring-----300 lb/in.
 At wheel-----110 lb/in.

Front Shock Absorbers:

Make and type ----- Delco, direct double acting
 Mounting----- Vertically from lower control arm
 through coil spring to front suspension crossmember
 Model number ----- 538F
 Valve code ----- 3.5G6/oxr/P 1.25
 Piston diameter and travel ----- 1.00x4.68

Rear Springs:

Make ----- Own
 Type ----- Semi-elliptic
 Material ----- Alloy steel
 Length and width ----- 51x2.0
 Spring clips ----- Clinch type-3
 Bolt type-1
 Total -4
 Number of leaves ----- 4
 Leaf thickness ----- Number 1 & 3----- .282
 Number 2----- .313
 Number 4----- .262
 Total ----- 1.159
 Capacity ----- At pad ----- 575 lb.
 At ground ----- 725 lb.

Rear Shock Absorbers:

Make & type ----- Delco, direct double acting
 Mounting ----- Stem attached to slotted
 holes in flanged "U" shaped rear
 crossmember, eye attached at
 bottom to an anchor bolt on rear
 spring "U" bolt and shock absorber
 anchor bolt plate.
 Model ----- .560P
 Valve code ----- 4D6/oxh/j 1.25
 Piston diameter and travel ----- 1.00x6.69

Steering:

Steering gear ratio ----- 16:1
 Steering wheel diameter ----- 17.25
 Turning diameters
 Right-wall to wall ----- 38.38 ft.
 Left-wall to wall ----- 38.99 ft.
 Right-curb to curb ----- 36.55 ft.
 Left-curb to curb ----- 36.93 ft.
 Overall steering ratio ----- 21:1

Drive Line:

Type----- Hotchkiss drive,
 one propeller shaft.

Rear Axle:

Type ----- Hypoid
 Ratio
 Conventional trans. - regular ----- 3.70:1
 optional ----- 4.11:1
 optional ----- 4.56:1
 Powerglide trans. ----- 3.55:1
 Gear combination
 Conventional trans. - regular ----- 37 & 10
 optional ----- 37 & 9
 optional ----- 41 & 9
 Powerglide trans. ----- 39 & 11

Total gear reduction

Axle	3.70:1		4.11:1		4.56:1	
Trans.	3-spd	4-spd	3-spd	4-spd	3-spd	4-spd
1st	8.18	8.18	9.08	9.08	10.07	10.07
2nd	4.88	6.14	5.46	8.82	6.02	7.57
3rd		4.85		5.38		5.97
Direct	3.70	3.70	4.11	4.11	4.56	4.56
Rev.	8.18	8.33	9.08	9.25	11.45	10.26

Powerglide

3.55:1 axle: drive----- 13.6:1-1:1
 low ----- 13.6:1-6.5:1
 reverse----- 13.6:1-6.5:1

Brakes-Service:

Type ----- Servo, 4 wheel hydraulic
 Brake size
 Front ----- 11x2
 Rear ----- 11x1 3/4
 Brake drums
 Diameter front & rear ----- 11
 Total effective area----- 259 sq. in.
 Lining sizes (length x width x thickness)
 Front-primary ----- 9.29x2.0x.175
 -secondary----- 11.69x2.0x.175
 Rear- primary ----- 9.29x1.75x.175
 - secondary ----- 11.69x1.75x.175
 Total lining effective area ----- 157 sq. in.
 Wheel cylinder bore
 Front----- 1.125
 Rear ----- 1.000
 Master cylinder bore----- 1.000
 Pedal travel----- 4.50
 Shoe clearance adjustment----- Adjust
 to light drag and back
 off seven notches.

Brakes - Parking:

Type of control ----- "T" handle pull rods
 Location of control----- L. H. of steering column
 Operate on ----- Rear service brakes
 Transmission: 3-speed data ----- See page P-61
 4-speed close ratio
 1st gear ----- 2.21:1
 2nd gear ----- 1.66:1
 3rd gear ----- 1.31:1
 4th gear ----- 1.00:1
 Powerglide ----- Same as passenger
 car Powerglide(See page P-62) except selector
 lever is mounted on floor to right of driver.

Tachometer:

Make ----- AC
 Model ----- W
 Type ----- Mechanical

**ENGINE - 283 CUBIC INCH EIGHT-CYLINDER
ENGINE GENERAL**

Engine	3-Speed transmission	Powerglide
Piston displacement (cu. in.)	283	
Type	Valve-in-head	
Number of cylinders	8	
Bore and stroke	3.875x3.00	
Compression ratio	9.5:1	
Taxable (SAE) horsepower	48	
Idling speed (RPM)	475 in neutral	475 in drive
Compression pressure (PSI)@ cranking speed, engine hot	160	
Dry weight (pounds)	Engine and clutch	557
	Engine, clutch & trans.	779
Lubrication	Full pressure	
Power plant mounting	Three point mounting, two front and one rear; combination compression and shear type	

ADVERTISED MAXIMUM ENGINE PERFORMANCE

Carburetor	4-barrel	Dual 4-barrel (optional)	Dual 4-barrel with special camshaft(optional)	Fuel injection (optional)	Fuel injection with special camshaft(optional)
Brake horsepower	Gross 230@ 4800 RPM	245@ 5000 RPM	270@ 6000 RPM	250@ 5000 RPM	290@ 6200 RPM
	Net 195@ 4600 RPM	215@ 4800 RPM	230@ 6000 RPM	225@ 4800 RPM	245@ 5600 RPM
Torque(lb. ft.)	Gross 300@ 3000 RPM	300@ 3800 RPM	285@ 4200 RPM	305@ 3800 RPM	290@ 4400 RPM
	Net 270@ 2800 RPM	270@ 3400 RPM	255@ 3800 RPM	280@ 3400 RPM	265@ 4200 RPM

ENGINE SPEED AND PISTON TRAVEL

Transmission	3-Speed close ratio transmission(regular prod.)			Powerglide(opt.)
Rear axle ratio	3.70:1*	4.11:1*	4.56:1*	3.55:1
Tire size	6.70-15(4 ply)			
Crankshaft revolutions per mile	2793.5	3103.1	3442.8	2680.3
Crankshaft RPM @ 1 MPH	Low & rev.	103.0	114.3	126.9
	Second	61.5	68.2	75.8
	Third‡	46.6	51.7	57.4
Piston travel(ft. per mile)	1396.8	1551.6	1721.4	1340.2
Transmission	4-Speed close ratio (optional)			
Rear axle ratio	3.70:1*	4.11:1*	4.56:1*	
Tire Size	6.70-15(4 ply)			
Crankshaft revolutions per mile	2793.5	3103.1	3442.8	
Crankshaft RPM@ 1 MPH	Low & rev.	102.5	113.7	126.3
	Second	77.4	85.8	95.3
	Third	61.0	67.7	75.2
	Fourth‡	46.6	51.7	57.4
Piston travel (ft. per mile)	1396.8	1551.6	1721.4	

‡ - Also known as the N/V factor.

* - Rear axle ratios are optional with Positraction (limited slip) differential carrier.

ENGINE - 283 CUBIC INCH EIGHT

ADVERTISED CAR PERFORMANCE

3-Speed Transmission	4 barrel carburetor	Dual 4-bbl. carburetor (optional)	Dual 4-bbl. carb. and special cam. (opt.)	Fuel injection (optional)	Fuel injection & special cam (opt.)
Model			867		
Performance weight (pounds)+	3204		3214		3191
Pounds/gross horsepower	13.93	13.12	11.90	12.78	11.00
Pounds/cu. in. piston displacement	11.33	11.36	11.36	11.24	11.24
Gross horsepower/cu. in. displacement	.813	.866	.954	.883	1.025
Power displacement (cu. ft. /mile)@	228.7	228.7	228.7	228.7	228.7
Displacement factor (cu. ft. /mile)*	142.76	142.94	142.94	143.34	143.34
Powerglide Transmission %					
Performance weight (pounds)+	3305	3314		3288	
Pounds/gross horsepower	14.37	13.53		13.15	
Pounds/cu. in. piston displacement	11.68	11.71		11.62	
Gross horsepower/cu. in. displacement	.813	.866		.883	
Power displacement (cu. ft. /mile)@	219.5	219.5		219.5	
Displacement factor (cu. ft. /mile)*	132.83	132.47		133.52	
4-Speed Transmission					
Performance weight (pounds)+	3217		3227		3204
Pounds/gross horsepower	13.90	13.17	11.95	12.82	11.05
Pounds/cu. in. piston displacement	11.37	11.40	11.40	11.32	11.32
Gross horsepower/cu. in. displacement	.813	.866	.954	.883	1.025
Power displacement (cu. ft. /mile)@	228.7	228.7	228.7	228.7	228.7
Displacement factor (cu. ft. /mile)*	142.18	141.74	141.74	142.76	142.76

- + - Curb weight plus 300 pounds (weight of two 150# passengers).
- % - Data computed assuming zero slippage in the torque converter.
- @ - $\frac{\text{Crankshaft revolutions per mile} \times \text{piston displacement} + 2}{1728}$
- * - Power displacement divided by performance weight in tons.

ENGINE PERFORMANCE

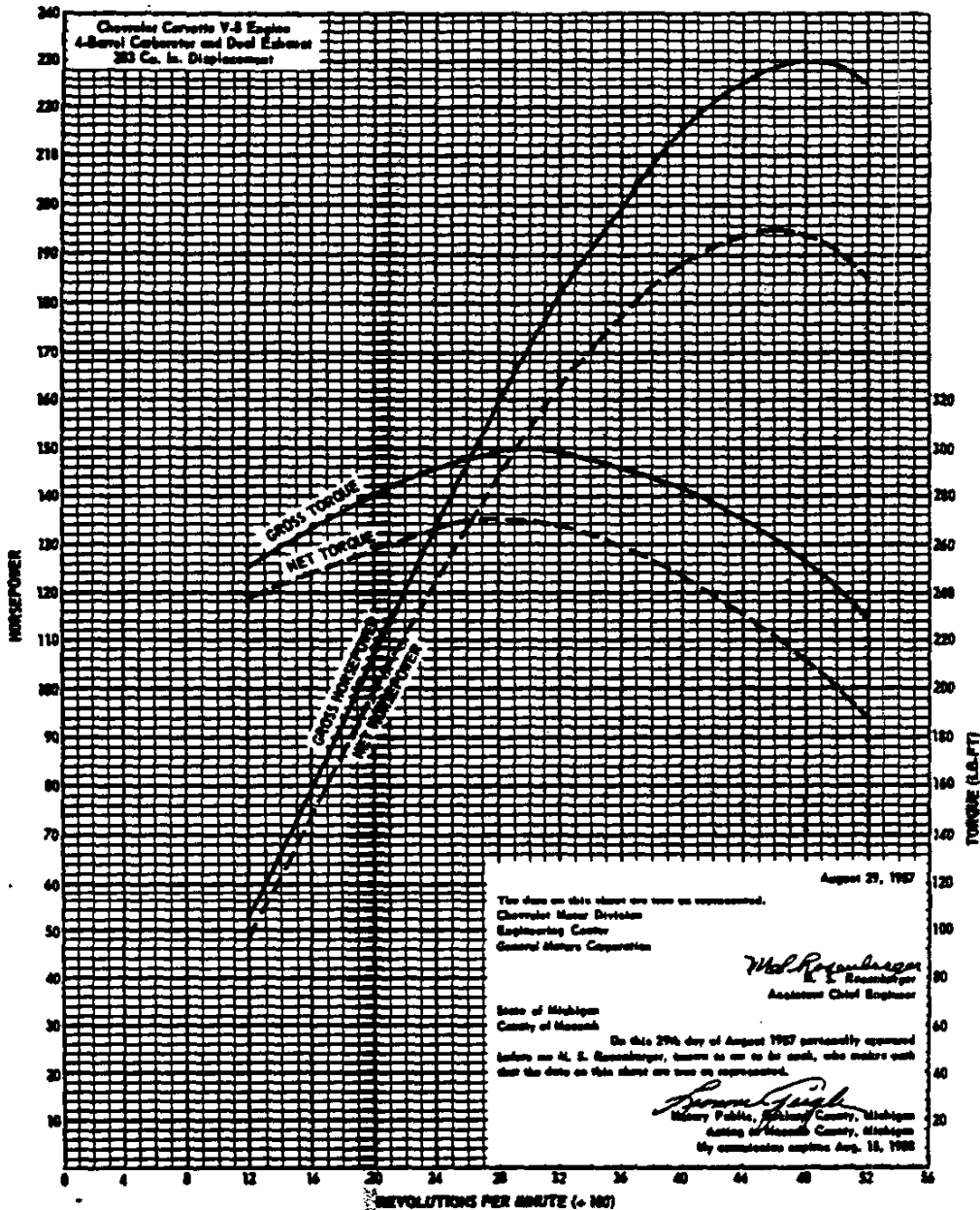

The engine performance curves shown on this sheet are taken from Chevrolet engine test report 17697-25. They represent the full throttle performance of a Chevrolet Corvette V-8 engine with 283 cubic inch displacement, as obtained from dynamometer test data corrected to standard barometric pressure of 29.92 inches of mercury and the standard temperature of 60°F.

GROSS POWER and TORQUE were obtained in a regular dynamometer test with the dynamometer exhaust system, no fan, generator not charging, and optimum spark advance.

GROSS POWER and TORQUE were obtained from a dynamometer test simulating actual operating conditions when the engine is in its vehicle. It includes the use of the regular mufflers and pipes, the fan in operation and automatic spark advance. The generator is not charging.

GROSS POWER and TORQUE were obtained in a regular dynamometer test with the dynamometer exhaust system, no fan, generator not charging, and optimum spark advance.

CHEVROLET 1958 SPECIFICATIONS - PASSENGER

ENGINE PERFORMANCE

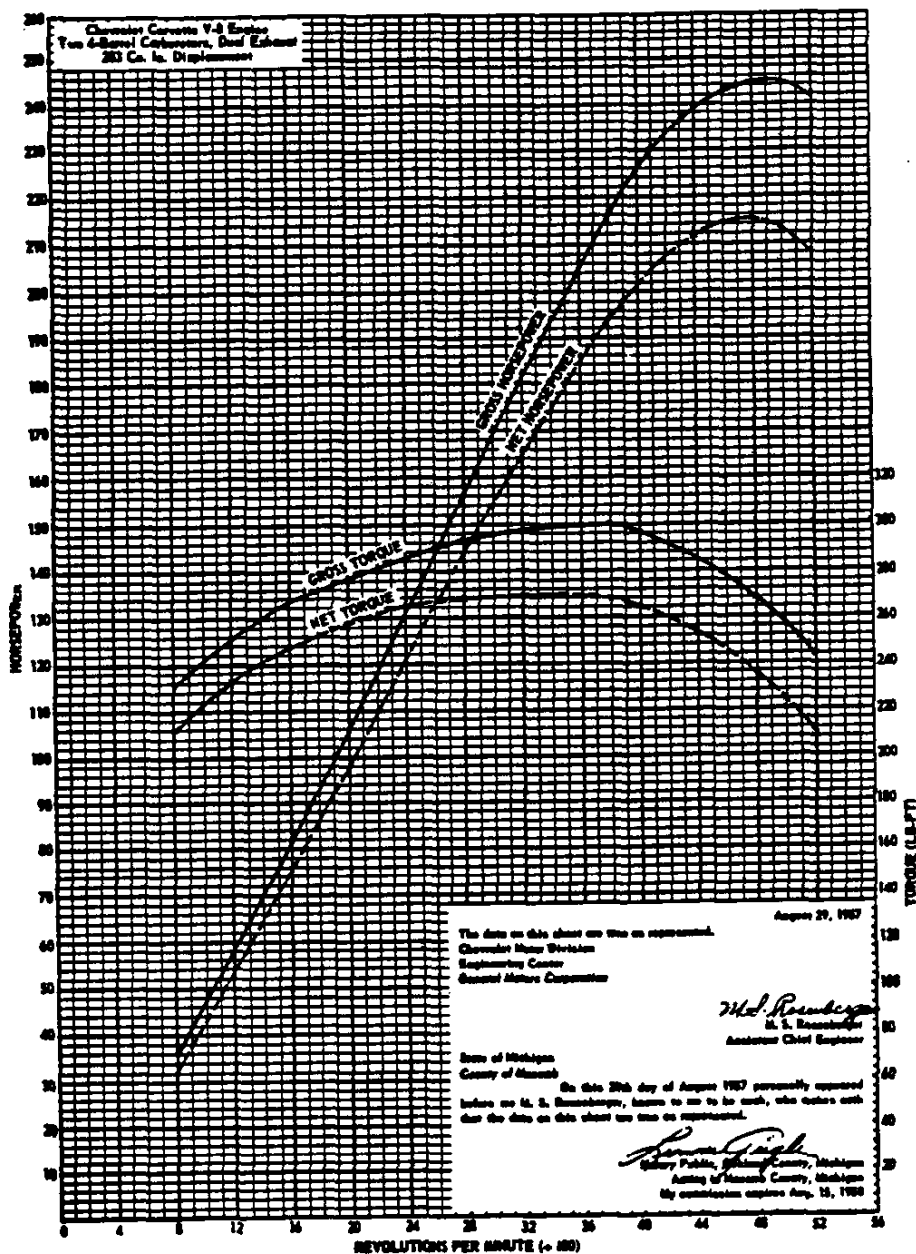

The engine performance curves shown on this sheet are taken from Chevrolet engine test report 17697-25. They represent the full throttle performance of a Chevrolet Corvette V-8 engine with 283 cubic inch displacement, as obtained from dynamometer test data corrected to standard barometric pressure of 29.92 inches of mercury and the standard temperature of 60°F.

GROSS POWER and TORQUE were obtained in a regular dynamometer test with the dynamometer exhaust system, no fan, generator not charging, and optimum spark advance.

GROSS POWER and TORQUE were obtained in a regular dynamometer test simulating actual operating conditions when the engine is in its vehicle. It includes the use of the regular mufflers and pipes, the fan in operation and automatic spark advance. The generator is not charging.

GROSS POWER and TORQUE were obtained in a regular dynamometer test with the dynamometer exhaust system, no fan, generator not charging, and optimum spark advance.

NET POWER and TORQUE were obtained from a dynamometer test simulating actual operating conditions when the engine is in its vehicle. It includes the use of the regular mufflers and pipes, the fan in operation and automatic spark advance. The generator is not charging.

GROSS POWER and TORQUE were obtained in a regular dynamometer test with the dynamometer exhaust system, no fan, generator not charging, and optimum spark advance.

GROSS POWER and TORQUE were obtained in a regular dynamometer test with the dynamometer exhaust system, no fan, generator not charging, and optimum spark advance.

NET POWER and TORQUE were obtained from a dynamometer test simulating actual operating conditions when the engine is in its vehicle. It includes the use of the regular mufflers and pipes, the fan in operation and automatic spark advance. The generator is not charging.

ENGINE PERFORMANCE

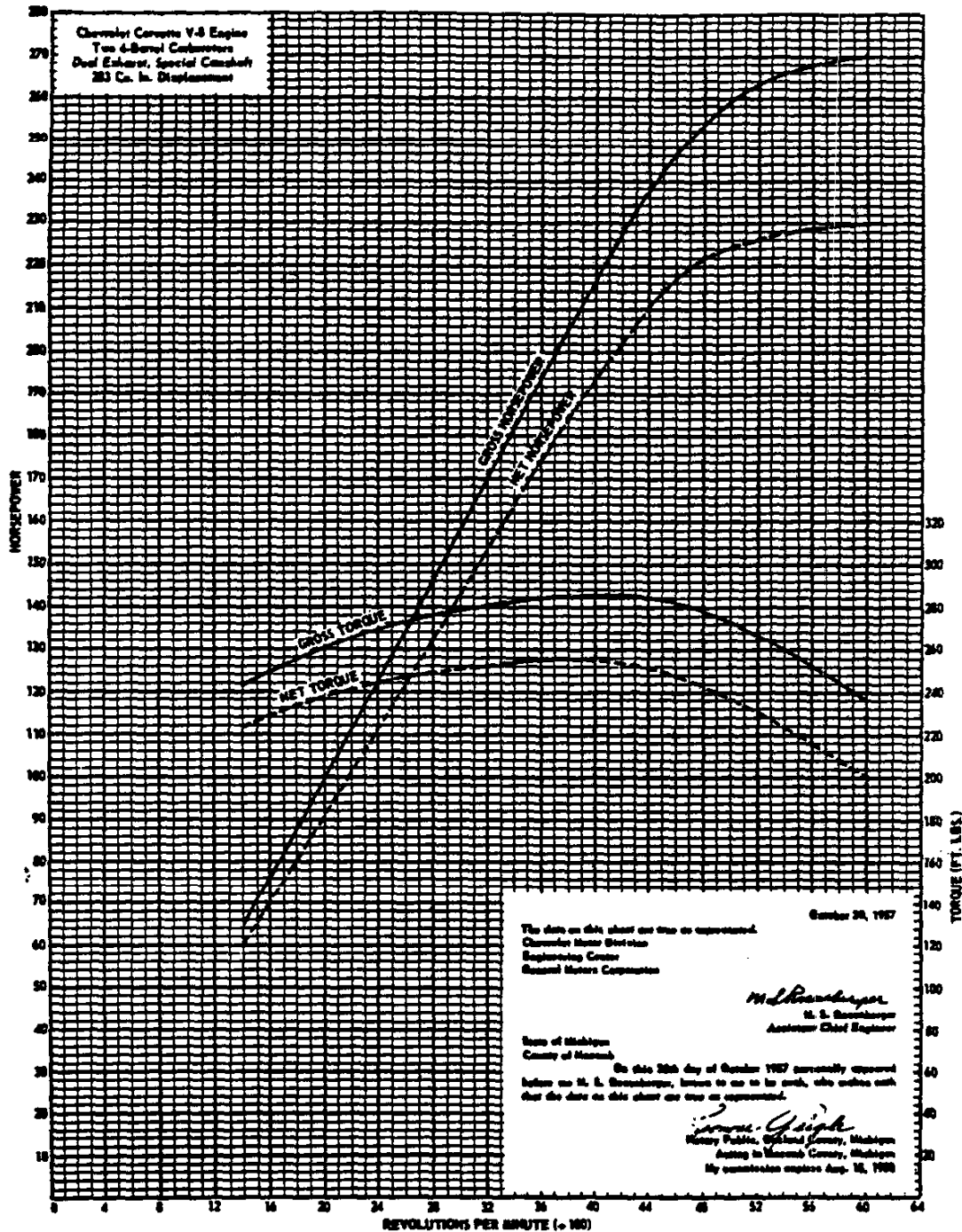

The engine performance curves shown on this sheet are taken from Chevrolet engine test report 17697-25. They represent the full throttle performance of a Chevrolet Corvette V-8 engine with 283 cubic inch displacement, as obtained from dynamometer test data corrected to standard barometric pressure of 29.92 inches of mercury and the standard temperature of 60°F.

GROSS POWER and TORQUE were obtained in a regular dynamometer test with the dynamometer exhaust system, no fan, generator not charging, and optimum spark advance.

11-29-57
P-76 - CORVETTE SUPPLEMENT

NET POWER and TORQUE were obtained from a dynamometer test simulating actual operating conditions when the engine is in its vehicle. It includes the use of the regular mufflers and pipes, the fan in operation and automatic spark advance. The generator is not charging.

CHEVROLET 1958 SPECIFICATIONS - PASSENGER

ENGINE PERFORMANCE

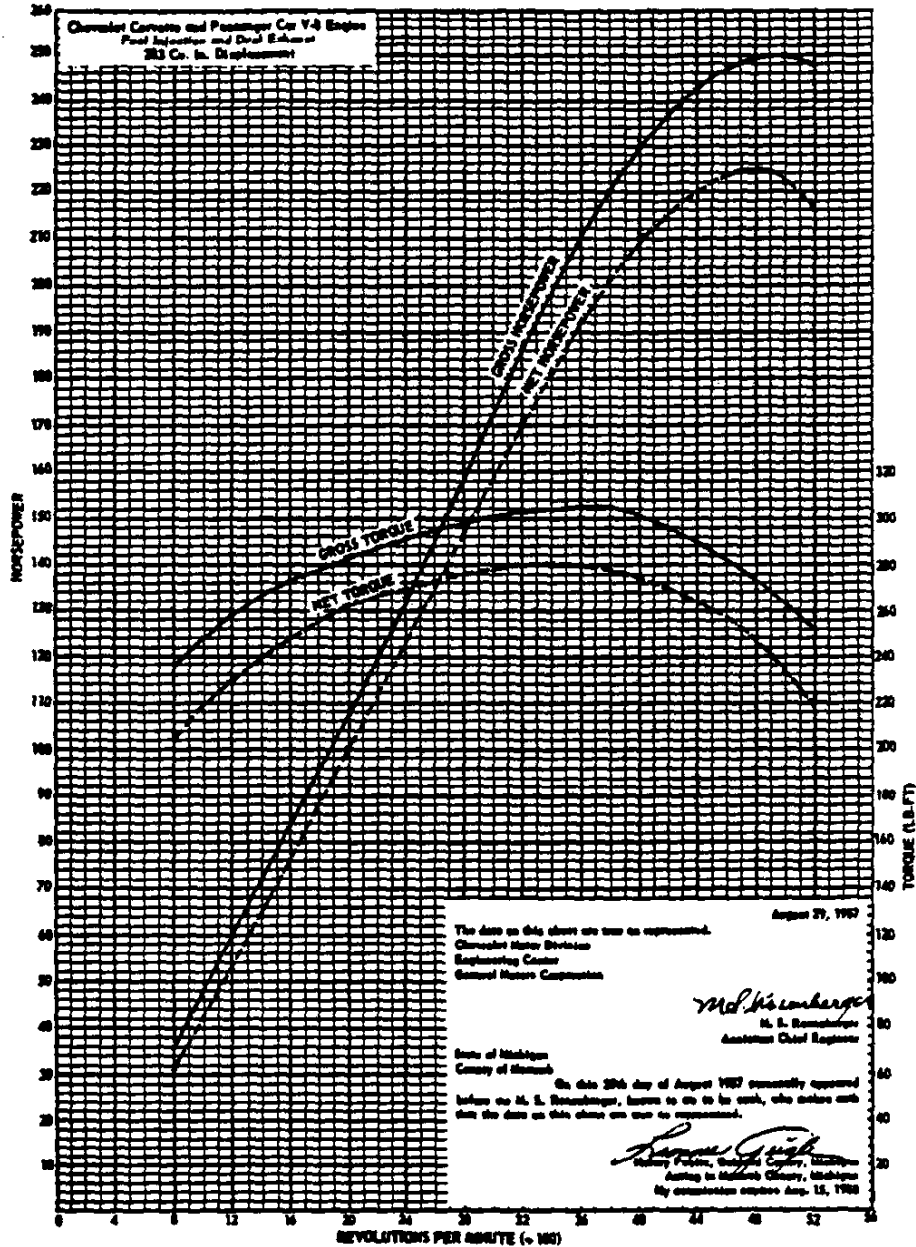

The engine performance curves shown on this sheet are taken from Chevrolet engine test report 17696-12. They represent the full throttle performance of a Chevrolet Corvette and passenger car V-8 engine with 283 cubic inch displacement, as obtained from dynamometer test data corrected to standard barometric pressure 29.92 inches of mercury and the standard temperature of 60°F.

ular dynamometer test with the dynamometer exhaust system, no fan, generator not charging, and optimum spark advance.

NET POWER and TORQUE were obtained from a dynamometer test simulating actual operating condition when the engine is in its vehicle. It includes the use of the regular mufflers and pipes, the fan in operation and automatic spark advance. The generator is not charging.

GROSS POWER and TORQUE were obtained in a regular dynamometer test with the dynamometer exhaust system, no fan, generator not charging, and optimum spark advance.
11-29-57
CHEVROLET 1958 SPECIFICATIONS - PASSENGER

ENGINE PERFORMANCE

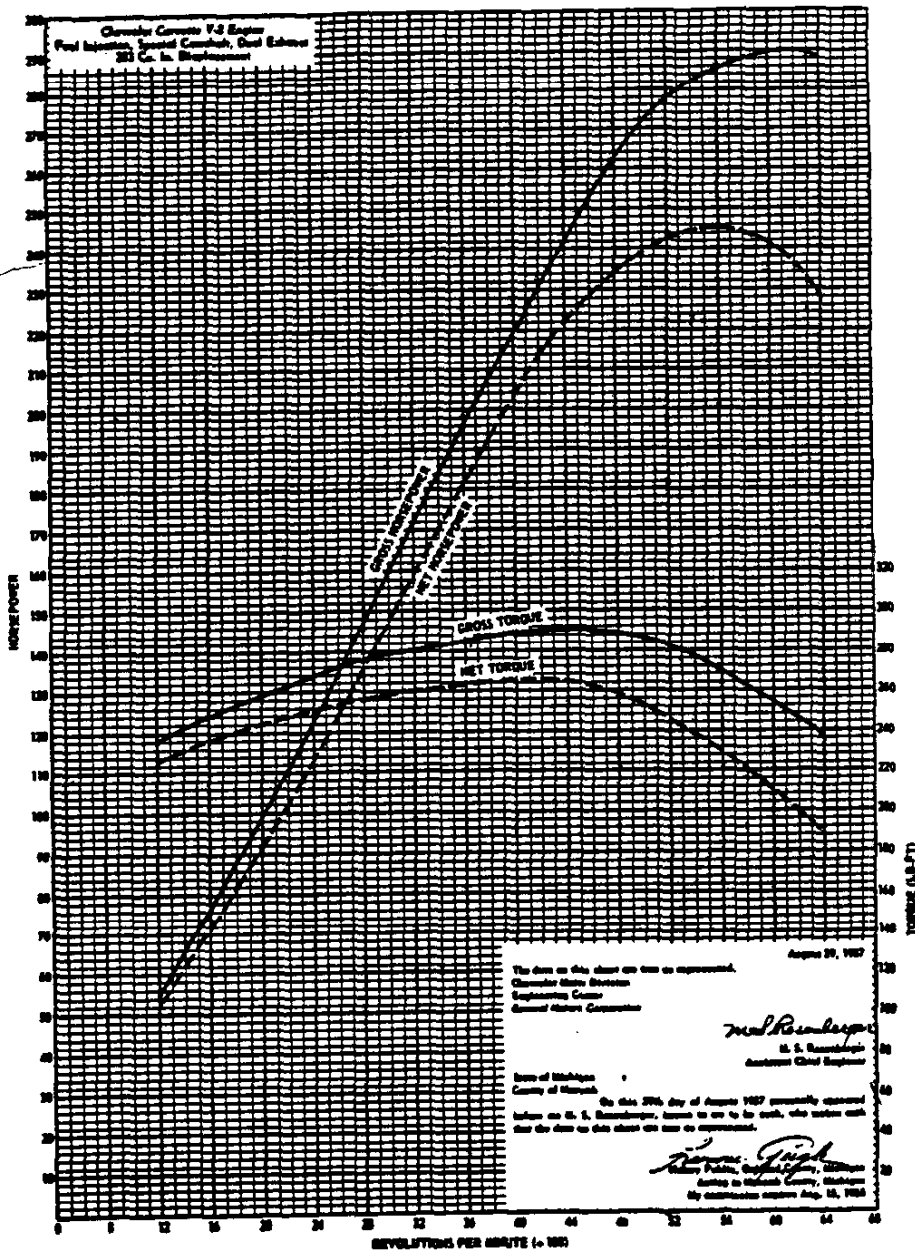

The engine performance curves shown on this sheet are taken from Chevrolet engine test report 17696-12. They represent the full throttle performance of a Chevrolet Corvette V-8 engine with 283 cubic inch displacement, as obtained from dynamometer test data corrected to standard barometric pressure of 29.92 inches of mercury and the standard temperature of 60°F.

GROSS POWER and TORQUE were obtained in a reg-11-29-57
 P-78 - CORVETTE SUPPLEMENT

ular dynamometer test with the dynamometer exhaust system, no fan, generator not charging, and optimum spark advance.

NET POWER and TORQUE were obtained from a dynamometer test simulating actual operating conditions when the engine is in its vehicle. It includes the use of the regular mufflers and pipes, the fan in operation and automatic spark advance. The generator is not charging.

CHEVROLET 1958 SPECIFICATIONS - PASSENGER

ENGINE - 283 CUBIC INCH EIGHT

ENGINE COMPONENTS

Upper Compression Ring:

Material ----- Cast alloy iron
 Width ----- .184-.194
 Thickness ----- .0775-.0780
 Gap ----- .010-.020
 Ring clearance in groove ----- .0012-.0017

Valve Springs:

Length and pressure
 Valve closed ----- 1.696@ 69-79 lb.
 Valve open ----- 1.306@ 159-169 lb.
 Free length ----- 2.08

Damper:

Number of coils ----- 3.87-4.12
 Free length ----- 2.00

Tappets:

Type ----- Hydraulic
 Material ----- Steel

Carburetor:

Make ----- Carter
 Type ----- 4 barrel, down-draft
 Choke ----- Automatic

Camshaft:

Ramp inlet
 Opening ----- .00474, 10° long
 Closing ----- .00670, 15° long
 Ramp exhaust
 Opening ----- .00474, 10° long
 Closing ----- .00670, 15° long
 Tappet lift
 Inlet ----- .26581
 Exhaust ----- .26581
 Valve lift
 Inlet ----- .3987
 Exhaust ----- .3987
 Valve lash
 Inlet ----- Zero
 Exhaust ----- Zero

Timing Diagram Data:

Inlet
 Opens (theoretical) ----- 12° 30' BTC
 Closes(theoretical) ----- 57° 30' ABC
 Exhaust
 Opens (theoretical) ----- 54° 30' BBC
 Closes(theoretical) ----- 15° 30' ATC

Clutch:

Type ----- Semi-centrifugal
 Number of coil springs ----- 9
 Spring pressure (lbs.) ----- 1620 initial
 Drive ----- Lug
 Lining area (sq. in.) ----- 90.72
 Rated torque capacity (lb. ft.) ----- 326

Air Cleaner:

Make and type ----- AC oil wetted
 Filter element ----- Aluminum wire

Oil Filter:

Make ----- AC, Full flow
 Capacity (quarts) ----- 1-1/2

Dual Exhaust System

Muffler type ----- Diffusion & resonance, reverse flow
 Body size ----- 24x4.06
 Manifold ----- Center take down each branch serving two cylinders.
 Exhaust pipe size O.D. ----- 2.0
 Tail pipe I.D. ----- 1.81
 Suspension ----- Individual, rubber insulated mountings.

Fuel System:

Fuel tank ----- Two stamped pans seam welded.
 Capacity (gallons) ----- 16.4
 Mounting ----- Supported by two straps attached to underbody behind seat.
 Filler ----- In body left side, to rear of drivers door.

Cooling System:

Radiator core, Make ----- Harrison
 Type ----- Cellular
 Size ----- .22x.550x2.00
 Frontal area (sq. in.) ----- 380
 Capacity ----- 16.5 qts. with heater

RADIATOR HOSES

	Cylinder head to radiator	Radiator to water pump outlet
Function	inlet	outlet
Material	fabric reinforced rubber	
Quantity	1	1
Type	molded elbow	compound curve
I. D.	1.50	1.75
Developed Length	16.50	15.00

OPTIONAL EQUIPMENT

Air Flow Heater ----- FOA 101
 Transistor Radio ----- FOA 102
 Parking Brake Alarm ----- FOA 107
 Courtesy Light ----- FOA 108
 Windshield Washer ----- FOA 109
 Wheels, 15x5-1/2 K ----- RPO 276
 6.70-15-4 PR Tires (Whitewall) ----- RPO 290
 Powerglide Transmission ----- RPO 313
 Auxiliary Hard Top ----- RPO 419
 Electric Windows ----- RPO 426
 Trim Combinations ----- RPO 440
 Dual Four Barrel Carburetor Equipment ----- RPO 469
 Folding Top Color Combination ----- RPO 470
 Hydraulic Lift Folding Top ----- RPO 473
 External Color Combinations ----- RPO 550-522
 Underbody Equipment ----- RPO 565
 Fuel Injection ----- RPO 579
 Limited Slip Differential (3.70) ----- RPO 677
 Limited Slip Differential (4.11) ----- RPO 678
 Limited Slip Differential (4.56) ----- RPO 679
 Heavy Duty Brake and Suspension ----- RPO 684
 Four-Speed Transmission Equipment ----- RPO 685

CORVETTE V-8 ENGINE (Dual Four Barrel Carburetor Equipment)

Specifications for this engine are the same as those for the conventional Corvette 283 except as listed below:

Crankshaft main bearings (with special camshaft):
 Material - Steel backed alum. alloy matrix with a thin lead alloy overplate except the rear main which is made of steel backed babbitt.

Connecting rod bearings (with special camshaft):
 Material - Steel backed alum. alloy matrix with a thin lead alloy overplate.

Special Camshaft (optional):
 Ramp, inlet
 Opening and closing0067, 18° long
 Ramp, exhaust
 Opening and closing0107, 29° long
 Tappet lift
 Inlet2625
 Exhaust2665
 Valve lift
 Inlet39375
 Exhaust39975
 Valve lash (high speed operation)
 Inlet012 hot
 Exhaust018 hot
 Valve lash (normal driving)
 Inlet008 hot
 Exhaust018 hot

Timing Diagram Data:
Special camshaft
 Inlet valve
 Opens 35° BTC
 Closes 72° ABC
 Exhaust valve
 Opens 76° BBC
 Closes 31° ATC

Distributor (special camshaft):
 Make Delco-Remy
 Model 1110915

Coil (special camshaft):
 Make Delco-Remy
 Model 1115091
 Location Top right side of engine
 Resistor type External

Valves (special camshaft):
Inlet
 Overall length 4.8799
 Overall head diameter 1.720
 End diameter3419
Exhaust
 Overall length 4.923
 Overall head diameter 1.500
 End diameter3414

Valve lifters (special camshaft):
 Type Mechanical

Carburetor:
 Make Carter
 Model, front 3744002
 rear 3744004
 Type 4 barrel

Piston:
 Skirt clearance0016-.0020

Air cleaner:
 Make AC
 Type Oil bath
 Capacity 1 pint
 Element Cactus fibre

Fuel strainer:
 Make AC
 Model 854272

Thriftmaster Special
Chevrolet Forward Control Truck Engine
235 Cu. In. Displacement

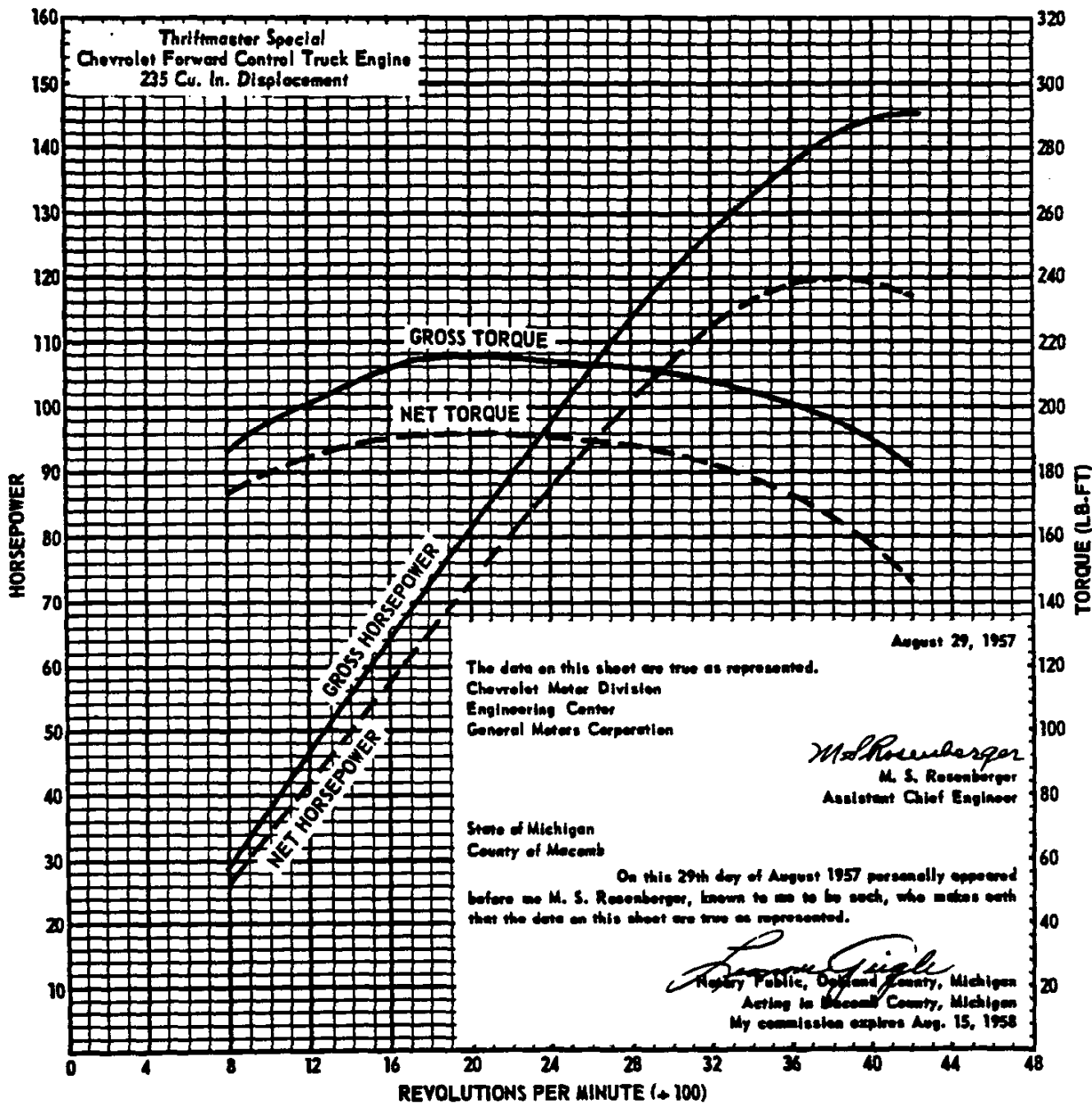

August 29, 1957

The data on this sheet are true as represented.
Chevrolet Motor Division
Engineering Center
General Motors Corporation

M. S. Rosenberger
M. S. Rosenberger
Assistant Chief Engineer

State of Michigan
County of Macomb

On this 29th day of August 1957 personally appeared before me M. S. Rosenberger, known to me to be such, who makes oath that the data on this sheet are true as represented.

Lawrence G. Gigh
Notary Public, Oakland County, Michigan
Acting in Macomb County, Michigan
My commission expires Aug. 15, 1958

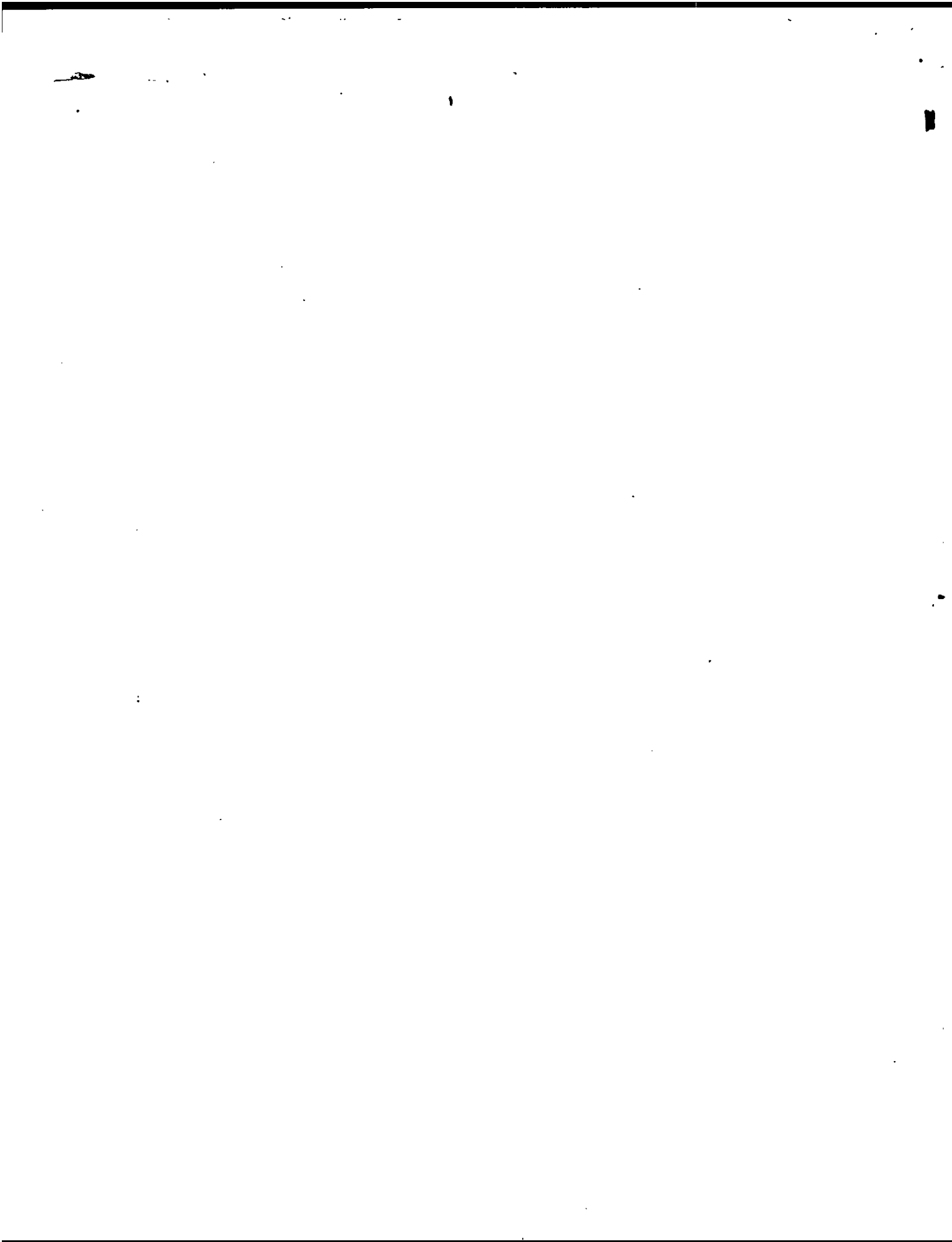

CORVETTE V-8 ENGINE (FUEL INJECTION)

Basic specifications for engines equipped with fuel injection are the same as those for the Corvette 283. In this system, the conventional carburetor is replaced by nozzles which inject fuel at the intake ports. Other differences in specifications are listed below:

Compression ratio (with special camshaft) ----- 10.5:1

Crankshaft main bearing (with special camshaft):
 Material - Steel backed alum. alloy matrix with a thin lead alloy overplate except the rear main which is made of steel backed babbit.

Connecting rod bearings (with special camshaft):
 Material - Steel backed alum. alloy matrix with a thin lead alloy overplate.

Special Camshaft (optional):

Ramp, inlet
 Opening and closing ----- .0067, 18° long
 Ramp, outlet
 Opening and closing ----- .0107, 29° long
 Tappet lift
 Inlet ----- .2625
 Exhaust ----- .2665
 Valve lift
 Inlet ----- .39375
 Exhaust ----- .39975
 Valve lash (high speed operation)
 Inlet ----- .012 hot
 Exhaust ----- .018 hot
 Valve lash (normal driving)
 Inlet ----- .008 hot
 Exhaust ----- .018 hot

Timing diagram data (special camshaft):

Inlet valve
 Opens ----- 35° BTC
 Closes ----- 72° ABC
 Exhaust valve
 Opens ----- 76° BBC
 Closes ----- 31° ATC

Distributor (special camshaft):

Make ----- Delco-Remy
 Model ----- 1110915

Valve lifters (special camshaft):

Type ----- Mechanical

Valves (special camshaft):

Inlet
 Overall length ----- 4.8799
 Overall head diameter ----- 1.720
 End diameter ----- .3419
 Exhaust
 Overall length ----- 4.923
 Overall head diameter ----- 1.500
 End diameter ----- .3414

Coil (special camshaft):

Make ----- Delco-Remy
 Model ----- 1115107
 Location ----- Top right side of engine
 Resistor type ----- External

Generator (special camshaft):

Make ----- Delco-Remy
 Model ----- 1102059
 Rating ----- 12 volts
 Mounting ----- Right side of engine

Pistons (special camshaft):

Make ----- Own
 Type ----- Slipper skirt
 Features ----- Domed head increases compression ratio. Recesses in head insure adequate valve clearance at high engine RPM.
 Skirt clearance ----- .0016-.0020

Manifold assembly, inlet

Material ----- Cast aluminum

Fuel:

System ----- Fuel injection
 Make ----- Rochester Products

Air cleaner:

Make ----- AC
 Type ----- Dry
 Element ----- Paper

Fuel filter:

Make ----- AC
 Model ----- GF 43
 Location ----- Mounted on engine top cover

Dual exhaust system (special camshaft):

Type ----- Straight thru

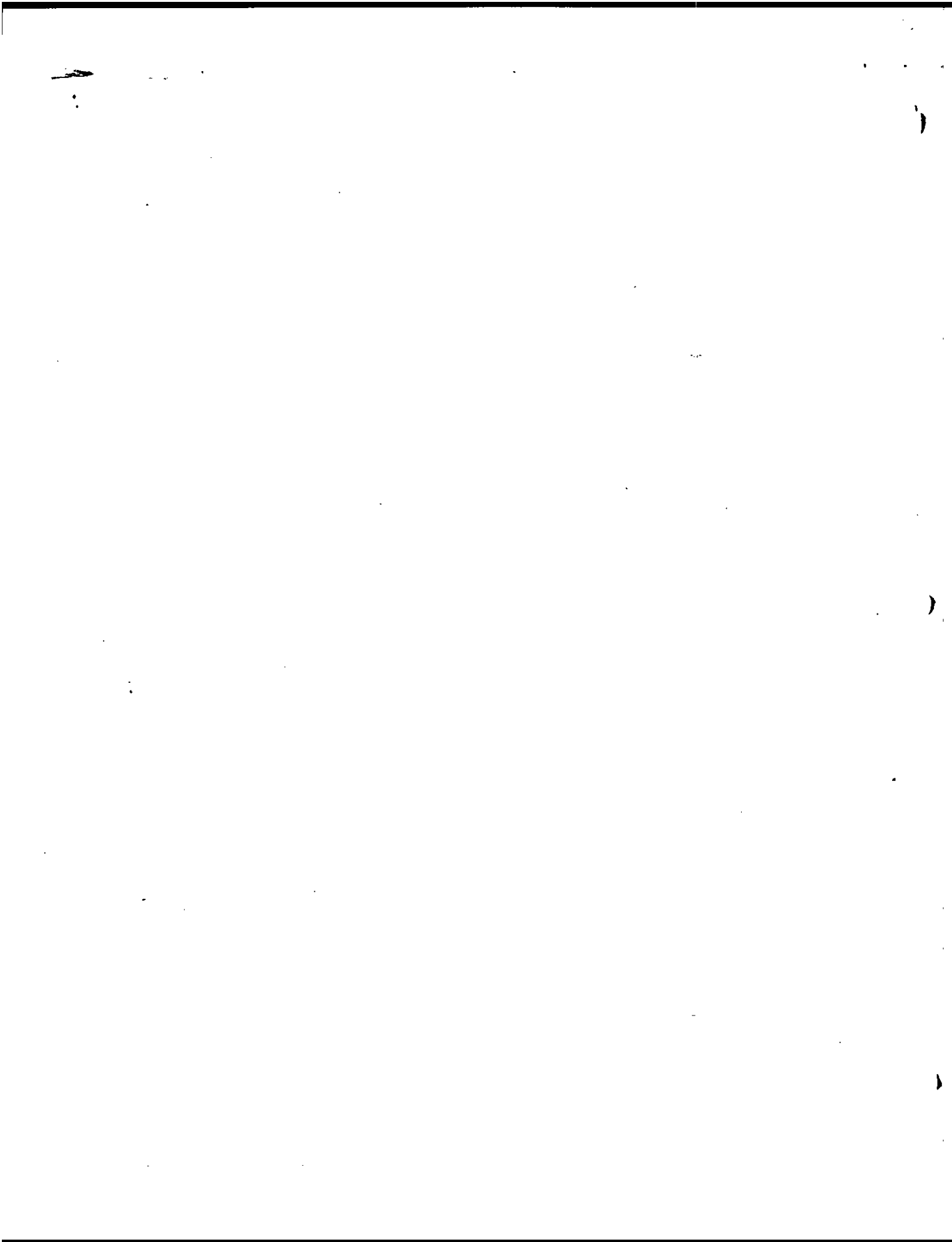

AMA Specifications – Passenger Car

Data prepared and distributed by American automobile manufacturers, using uniform questionnaire form developed by car manufacturers under auspices of the Automobile Manufacturers Association.

MAKE OF CAR	CHEVROLET	MODEL YEAR	1958	DATE ISSUED	8-27-57	REVISED	10-31-57
COMPANY	CHEVROLET DIVISION GENERAL MOTORS CORP.						
MODEL NAME	CORVETTE		SYMBOL	E67		MQ	
							ORIGINAL COPY

TABLE OF CONTENTS

General Specifications	1	Brakes	15	Station Wagon	24
Engine - Mechanical	2	Front Suspension & Steering	16	Body & Car - General	25
Electrical	8	Rear Suspension	18	Weights	26
Drive Units	12	Body Dimensions	19	Index	27

NOTES:

1. The specifications set forth herein are those in effect at the date of compilation and are subject to change without notice.

UNLESS OTHERWISE INDICATED:

- All specifications are standard for the models under which they are listed.
- Specifications apply basically to 4-door sedan or equivalent. Body dimensions shown on pages 19-24 include other body models available.
- All dimensions are nominal engineering dimensions.

GENERAL SPECIFICATIONS

MODEL	Additional Information Page No.:	
		283 CURVE INCH V-8
Wheelbase (L-101)	22	102
Tread	Front (W-101)	57.0
	Rear (W-102)	59.0
Maximum Overall Dimensions	Length (L-103)	177.2
	Width (W-103)	72.8
	Height (H-101)	51.1 PENDING TOP UP (a)
Transmission— (Specify trade name - opt., not available)	Manual	3-SPEED CLOSE RATIO STANDARD (e)
	Overdrive	NONE
	Automatic	POWERGLIDE OPTIONAL
Axle ratio	Manual	3.70:1 (b)
	Overdrive	NONE
	Automatic	3.55:1
Tire size	15	6.70-15-11 PLY BLACKWALL STD.
Engine	Type, no. cyl., valve arr.	900 V-8, TV HEAD
	Fuel system (Carb. or inj.)	CARBURETOR (c)
	Bore and stroke	3.875 X 3.00
	Piston displ., cu. in.	283
	Std. compression ratio	9.5:1 (d)
	Max. bhp at engine rpm	230 @ 1800 RPM
	Max. torque at rpm	300 @ 3000 RPM

- (a) 51.0 OPTIONAL HARDTOP
- (b) 4.11:1 & 4.56:1 POSITRACTION REAR AXLES RATIOS OPTIONAL FOR 3 OR 4 SPEED TRANS.
- (c) DUAL 4-BARREL CARBURETOR OR FUEL INJECTION OPTIONAL
- (d) 10.5:1 WITH FUEL INJECTION & SPECIAL CAMSHAFT OPTION
- (e) 4 SPEED TRANSMISSION OPTIONAL

AMA Specifications – Passenger Car

MAKE OF CAR CHEVROLET MODEL YEAR 1958 DATE ISSUED 8-27-57 REVISED 10-31-57

MODEL CORVETTE

ENGINE—GENERAL

Type, no. cyls., valve arr.		90° V-8, IN HEAD
Bore and stroke		3.875 X 3.00
Piston displacement, cu. in.		283
Bore spacing (C/L to C/L)		11.1
No. system (front to rear)	L. Bank	1-3-5-7
	R. Bank	2-4-6-8
Firing order		1-8-4-3-6-5-7-2
Compres. ratio (nominal)	Standard	9.5:1
	Optional	10.5:1 WITH FUEL INJECTION AND SPECIAL CAM
Cylinder Head Material	Standard	CAST ALLOY IRON
	Optional	NONE
Cylinder Sleeve – Wet, dry, none		NONE
Number of mounting points	Front	2
	Rear	1
Taxable Dia. ² x No. Cyl. horsepower 2.5		48
Published max. bhp at engine RPM*	Standard	230 @ 4800 RPM
	Optional	(b)
Published max. torque (lb. ft. @ RPM)	Standard	300 @ 3000 RPM
	Optional	(b)
Recommended fuel regular – premium	Standard	91-96 PREMIUM OCTANE (a)
	Optional	NONE
Recommended idle speed (neutral)		475 IN NEUTRAL WITH 3-SPEED; 425 IN DRIVE WITH POWERGLIDE

ENGINE—PISTONS

Material	CAST ALUMINUM ALLOY
Description and finish	MACHINED RELIEF FOR VALVE HEAD CLEARANCE (DOMED PISTON WITH MACHINED RELIEFS WITH FUEL INJECTION AND SPECIAL CAMSHAFT)
Weight (piston only, oz.)	21.12

* Max. bhp (brake horsepower) and max. torque corrected as defined by SAE Engine Test Code.

(Continued)

Rev. Form 6-57

(a) 96-100 PREMIUM OCTANE WITH FUEL INJECTION & SPECIAL CAMSHAFT.

(b) See Page 2-A

AMA Specifications – Passenger Car

MAKE OF CAR CHEVROLET MODEL YEAR 1958 DATE ISSUED 8-27-57 REVISED 10-31-57

MODEL CORVETTE

ENGINE PISTONS (Cont.)

Clearance (limits)	Top land		.035-.043
	Skirt	Top	.0016-.0020
		Bottom	N.A.
Ring groove depth	No. 1 ring		.2153-.2218
	No. 2 ring		.2153-.2216
	No. 3 ring		.2093-.2158
	No. 4 ring		NONE

ENGINE-RINGS

Function (top to bottom)	No. 1, oil or comp.		COMPRESSION
	No. 2, oil or comp.		COMPRESSION
	No. 3, oil or comp.		OIL
	No. 4, oil or comp.		NONE
Compression	Description - material, type, coating, etc.		INSIDE SEVEL, CAST ALLOY IRON, CHROME PLATED O.D.
	Width		.0775-.0780
	Gap		.010-.020
Oil	Description - material, type, coating, etc.		STAINLESS STEEL SPACER MULTI-PIECE, STEEL RAILS, WITH CHROME PLATED O.D.
	Width		.181-.188
	Gap		.015-.055
Expanders			IN OIL RING ASSY.

ENGINE-PISTON PINS

Material			CHROMIUM STEEL
Length			2.990-3.010
Diameter			.9270-.9273
Type	Locked in rod, in piston, floating, etc.		PRESSED IN ROD
	Bushing	In rod or piston	NONE
		Material	NONE
Clearance	In piston		.00015-.00025
	In rod		NONE
Direction & amount offset in piston			MAJOR THRUST SIDE - .060

ENGINE-CONNECTING RODS

Material			FORGED STEEL
Weight (oz.)			19.02
Length (center to center)			5.699-5.701
Bearing	Material & Type		STL. BACKED BABBITT (2), REMOVABLE
	Overall length		.817
	Clearance (limits)		.0007-.0027
	End play		.008-.014

(2) STEEL BACKED ALUMINUM ALLOY MATRIX WITH THIN LEAD ALLOY OVERPLATE, REMOVABLE, WITH SPECIAL CAMSHAFT.

AMA CONSOLIDATED SPECIFICATION QUESTIONNAIRE

MAKE OF CAR Chevrolet

MODEL YEAR 1958

MODEL Corvette

ENGINE GENERAL (Continued)

With Four-Barrel Carburetor Equipment:

Maximum bhp at engine RPM
Maximum torque at RPM

230 @ 4800
300 @ 3000

With Two Four-Barrel Carburetor Equipment:

Maximum bhp at engine RPM
Maximum torque at RPM

245 @ 5000
300 @ 3800

With Fuel Injection Equipment:

Maximum bhp at engine RPM
Maximum torque at RPM

250 @ 5000
305 @ 3800

With Two Four Barrel Carburetor and Special Camshaft:

Maximum bhp at engine RPM
Maximum torque at RPM

270 @ 6000
285 @ 4200

With Fuel Injection and Special Camshaft:

Maximum bhp at engine RPM
Maximum torque at RPM

290 @ 6200
290 @ 4400

AMA Specifications - Passenger Car

NAME OF CAR CHEVROLET MODEL YEAR 1958 DATE ISSUED 8-27-57 REVISED 10-31-57

MODEL CORVETTE

ENGINE-CRANKSHAFT

Material		FORGED STEEL		
Vibration damper type		INERTIA, RUBBER MOUNTED		
End thrust taken by bearing (No.)		5		
Crankshaft end play		.002-.006		
Main bearing	Material & type	STEEL BACKED BABBITT, REMOVABLE (d)		
	Clearance	.0008-.0034		
	Journal dia. and bearing overall length	No. 1	2.2983 X .7620	
		No. 2	2.2983 X .7620	
		No. 3	2.2983 X .7620	
		No. 4	2.2983 X .7620	
		No. 5	2.2983 X 1.169	
		No. 6	NONE	
No. 7		NONE		
Dir. & amt. cyl. offset		NONE		
Crankpin journal diameter		1.999-2.000		

ENGINE-CAMSHAFT

Location		ABOVE CRANKSHAFT		
Material		CAST ALLOY IRON		
Bearings	Material	BABBITT ON STEEL BACKED ALUMINUM SHELL		
	Number	5		
Gear or chain		CHAIN AND SPROCKET		
Type of drive	Crankshaft gear or sprocket material		STEEL	
	Camshaft gear or sprocket material		CAST ALLOY IRON	
	Timing chain	No. of links	46	
		Width	.875	
		Pitch	.500	

ENGINE-VALVE SYSTEM

Hydraulic lifters (Std, opt, NA)		STANDARD (a)	
Special provision for valve rotation (Intake, exhaust)		NONE	
Rocker ratio		1.5:1	
Operating tappet clearance (Indicate hot or cold)	Intake	ZERO (b)	
	Exhaust	ZERO (c)	
Timing marks on fly-wheel, damper, other		DAMPER	

- (a) MECHANICAL TAPPETS ON ENGINES EQUIPPED WITH SPECIAL CAMSHAFT (Continued) Rev. Form 6-57
- (b) .012 HOT WITH MECHANICAL TAPPETS
- (c) .018 HOT WITH MECHANICAL TAPPETS
- (d) STEEL BACKED ALUMINUM ALLOY MATRIX WITH THIN LEAD ALLOY OVERPLATE, REMOVABLE, WITH SPECIAL CAMSHAFT.

AMA Specifications - Passenger Car

MAKE OF CAR CHEVROLET MODEL YEAR 1958 DATE ISSUED 8-27-57 REVISED 10-31-57

MODEL CORVETTE

ENGINE-VALVE SYSTEM (cont.)

Timing	Intake	Opens (°BTC)	12° 30' SPECIAL CAMSHAFT	35°
		Closes (°ABC)	57° 30' SPECIAL CAMSHAFT	72°
		Duration - deg.	250° SPECIAL CAMSHAFT	287°
	Exhaust	Opens (°BSC)	51° 30' SPECIAL CAMSHAFT	76°
		Closes (°ATC)	15° 30' SPECIAL CAMSHAFT	31°
		Duration - deg.	250° SPECIAL CAMSHAFT	287°
	Valve opening overlap		28°	66°
Material		ALLOY STEEL		
Overall length		4.9024-4.9224 (a)		
Actual overall head dia.		1.715-1.725		
Angle of seat		15°		
Seat insert material		NONE		
Stem diameter		.3415-.3422		
Stem to guide clearance		.0010-.0027		
Intake	Lift		.3987 (.3818 WITH SPECIAL CAMSHAFT)	
	Outer spring press. and length	Valve closed (lb. @ in.)	1.696 @ 71-79 LB.	
		Valve open (lb. @ in.)	1.30 @ 159-169 LB.	
	Inner spring press. and length	Valve closed (lb. @ in.)	VALVE SPRING DAMPER 5-10 LB.	
		Valve open (lb. @ in.)	N.A.	
	Material		ALLOY STEEL	
Overall length		1.913-1.933 (b)		
Actual overall head dia.		1.495-1.505		
Angle of seat		15°		
Seat insert material		NONE		
Stem diameter		.3410-.3417		
Stem to guide clearance		.0015-.0032		
Exhaust	Lift		.3987 (.3817 WITH SPECIAL CAMSHAFT)	
	Outer spring press. and length	Valve closed (lb. @ in.)	71-79 LB. @ 1.696	
		Valve open (lb. @ in.)	159-169 @ 1.306	
	Inner spring press. and length	Valve closed (lb. @ in.)	VALVE SPRING DAMPER 5-10 LB.	
		Valve open (lb. @ in.)	N.A.	
	Material		ALLOY STEEL	
Overall length		1.913-1.933 (b)		
Actual overall head dia.		1.495-1.505		
Angle of seat		15°		
Seat insert material		NONE		
Stem diameter		.3410-.3417		
Stem to guide clearance		.0015-.0032		
Lift		.3987 (.3817 WITH SPECIAL CAMSHAFT)		
Outer spring press. and length	Valve closed (lb. @ in.)	71-79 LB. @ 1.696		
	Valve open (lb. @ in.)	159-169 @ 1.306		
Inner spring press. and length	Valve closed (lb. @ in.)	VALVE SPRING DAMPER 5-10 LB.		
	Valve open (lb. @ in.)	N.A.		

ENGINE-LUBRICATION SYSTEM

Type of lubrication (splash, pressure, nozzle)	Main bearings	PRESSURE
	Connecting rods	PRESSURE
	Piston pins	SPASH
	Camshaft bearings	PRESSURE
	Tappets	PRESSURE
	Timing gear or chain	PRESSURE
	Cylinder walls	PRESSURIZED JET CROSS SPRAYED

- (a) 4.8699-4.8899 WITH DUAL 4-BARREL OR FUEL INJECTION WITH SPECIAL CAMSHAFT (Continued) Rev. Form 6-57
- (b) 4.8905-4.9105 WITH DUAL 4-BARREL OR FUEL INJECTION WITH SPECIAL CAMSHAFT

AMA CONSOLIDATED SPECIFICATION QUESTIONNAIRE

Revised: 10-31-57

Make of Car CHEVROLET Model Year 1958Model CORVETTE

ENGINE FUEL SYSTEM-FUEL INJECTION

Injection System	Make	Rochester Products
	Model	7014900
	Type	Constant Flow
Fuel Recommended		Premium
Fuel Pump	Type	Mechanical
	Location	Lower Right Front Corner of Engine
	Pressure Range	5-1/4 - 6-1/2 PSI
Auxiliary Fuel Filter	Type	Ten Micron
	Location	Bracketed to Engine Top Cover RH Front
Inlet Manifold Adapter-Material		Cast Aluminum
Inlet Manifold-Material		Cast Aluminum
Air Induction (a)	Air Cleaner Type	Dry (Paper Element)
	Air Meter Location	Left Side of Engine
	Plenum Chamber	Integral with Inlet Manifold
	Ran Pipes	Eight, Integral with Inlet Manifold
	Ran Pipe Length	12 Inches
Fuel Induction		Metered as Function of Air Flow
Air/Fuel Ratio Control		Vacuum Sensitive Diaphragm Located on Fuel Meter
Fuel Meter Pump	Type	Gear Type
	Location	In Fuel Meter Assembly
	Drive	Gear Driven by Flexible Shaft from Distributor
	Pressure (Max.)	300 PSI
Injection Nozzles	Number Used	Eight
	Material	Brass
	Location	Mounted on Inlet Manifold above Intake Ports
	Orifice Size-Fuel	.0118
	Insulation	Bakelite Block
Automatic Enrichment	Type	Electric, Time-Temperature Type
	Location	On Air Meter Assembly
	Current Draw	1 amp. at 70°
Fast Idle Cam		Yes

(a) - Air Intake Ducts which channel outside air to the Engine Compartment, are furnished with fuel injection when special camshaft is used.

AMA Specifications – Passenger Car

MAKE OF CAR Chevrolet MODEL YEAR 1958 DATE ISSUED 9-27-57 REVISED 10-31-57

MODEL Corvette

ENGINE—LUBRICATION SYSTEM (cont.)

Oil pump type	Gear
Normal oil pressure (lb. @ engine rpm)	35 - PSI @ 2000
Oil pressure sending unit (electric or mechanical)	Electric
Type oil intake (floating, stationary)	Stationary
Oil filter system (full flow, partial, other)	Full Flow
Filter replacement (element, complete)	AC Element
Capacity of crankcase, less filter-refill (qt.)	5
Oil grade recommended (SAE viscosity and temperature range)	Not Lower Than 32° F..... SAE 20W or SAE 20 Not Lower Than 0° F..... SAE 10W or SAE 10W-30 Lower Than 0° F..... SAE 5W or SAE 5W-20
Oil type recommended	Heavy Duty

ENGINE—EXHAUST SYSTEM

Type (single, single with cross-over, dual, other)	Dual
Muffler No. & type (reverse flow, straight thru, separate resonator)	Reverse Flow (a)
Exhaust pipe dia. (O.D. Branch wall thickness)	None
	2.00 x .0625
Exhaust pipe dia. (O.D. Main wall thickness)	1.31 x .0598
Tail pipe diameter (O.D. & wall thickness)	1.31 x .0598

ENGINE—FUEL SYSTEM

(See Supplement to Page 6 for Details of Fuel Injection, Supercharger, etc. if used)

Induction type: Carburetor, fuel injection, supercharger.	Carburetor (Fuel Injection Optional)	
Fuel Tank	Capacity (gals.)	16.4
	Filler location	Left Side Of Body To Rear Of Drivers Door
Fuel Pump	Type (elec. or mech.)	Mechanical
	Locations	Lower Right Front Corner Of Engine
	Pressure range	5.25-6.5 PSI
Vacuum booster (std., optional, none)	None	
Fuel Filter	Type	Strainer
	Locations	Ahead Of Carburetor
Carburetor	Make & Model No.	Carter 3746384
	Number & Type	Single 4-Barrel (Dual 4-Barrel Optional)
	Barrel size	1.4375
	Choke type	Automatic
	Intake manifold heat control (exhaust or water)	Exhaust
	Air clnr. type	Oil Wetted Paper Element with Fuel Injection

(a) - Straight through with special camshaft.

AMA Specifications - Passenger Car

MAKE OF CAR Chevrolet MODEL YEAR 1958 DATE ISSUED 8-27-57 REVISED 10-31-5

MODEL Corvette

ENGINE-COOLING SYSTEM

Type (pressure system, atmospheric, other)		Pressure	
Radiator cap relief valve pressure		6.25-7.75 PSI	
Circulation thermostat	Type (choke, bypass)	Choke	
	Starts to open at (°F)	160	
Water pump	Type (centrifugal, other)	Centrifugal	
	Number of pumps	One	
	Drive (V-belt, other)	V-Belt	
	Bearing type	Double Row Ball	
By-pass recirculation type (internal, external)		Internal	
Radiator core type (cellular, tube and fin, other)		Cellular	
Cooling system capacity	With heater (qt.)	17	
	Without heater (qt.)	16	
	Opt. equipment-specify (qt.)	None	
Water jackets full length of cylinder (yes, no)		Yes	
Water all around cylinder (yes, no)		Yes	
Radiator hose	Lower	Number and type (molded, straight)	One, Moulded
		Inside diameter	1-3/4
	Upper	Number and type (molded, straight)	One, Moulded
		Inside diameter	1-1/2
	By-pass	Number and type (molded, straight)	None
		Inside diameter	None
Fan	Number of blades & Spacing		4-Staggered
	Diameter		17
	Ratio-fan to crankshaft rev.		.949:1
	Fan cutout type		None
	Bearing type		Double Row Ball
*Drive belts (Indicate belt used by letter)	Fan		A
	Generator		A
	Water Pump		A
	Power Steering		NA
	Air Conditioning		NA

Rev. Form 6-57

*Drive Belt Dimensions	A	B	C
Angle of V	37°-44°		
Nominal length (SAE)	54-3/4		
Width	5/16		

AMA Specifications – Passenger Car

MAKE OF CAR Chevrolet MODEL YEAR 1958 DATE ISSUED 8-27-57 REVISED 10-31-57

MODEL Corvette

ELECTRICAL—SUPPLY SYSTEM

Battery	Make and Model		Delco, 2 SKR 53-W
	Voltage Rtg. & Plates/cell		12 Volt, 9-Plate
	SAE Designation & Amp Hr. Rtg		2 SK, 53 Amp. Hrs. & 20 Hr.
	Location		Under Hood Right Side Rear
Terminal grounded		Negative	
Generator	Make		Delco-Remy
	Model		11C2043
	Type		2 Brush, Shunt Wound
	Ratio—Gen. to Cr/s rev.		2.00:1
	Gen. cut-in—engine rpm		1250
Regulator	Make		Delco-Remy
	Model		1119001
	Type		Current & Voltage Regulator
	Cutout relay	Closing voltage @ generator rpm	11.8-13.5 @ 1300 RPM
		Reverse current to open	NA
	Regulated	Voltage	13.8-14.8
		Current	27-33 AMP
	Voltage test conditions	Temperature	Operating (Run Gen. 15 Min. & 8-10 Amps. Before Testing)
Load		10 Amps. Max.	
Other		None	

ELECTRICAL—STARTING SYSTEM

Starting motor	Make		Delco-Remy
	Model		1107664
	Rotation (drive end view)		Clockwise
	Engine cranking speed		NA
	Test conditions		Engine At Operating Temperature
	Lock test	Amps	NA
		Volts	NA
		Torque (lb. ft.)	NA
	No load test	Amps	75 (Max.)
		Volts	10.3
RPM (min.)		6900	
Motor control	Switch (solenoid, manual)	Solenoid	
	Starting procedure	3-Speed-Shift in Neutral, Depress Clutch Powerglide-Place Selector Lever in Park Or Neutral To Start Engine, Depress Accelerator Pedal To Floor And Release. Turn Ignition Key To Extreme Right.	

AMA Specifications - Passenger Car

MAKE OF CAR Chevrolet MODEL YEAR 1958 DATE ISSUED 8-27-57 REVISED 10-31-57

MODEL Corvette

ELECTRICAL-STARTING SYSTEM (cont.)

Motor drive	Engagement type	Positive Shift Solenoid	
	Pinion meshes (front, rear)	Front	
	Number of teeth	Pinion	9
		Flywheel	168
	Flywheel tooth face width	.4135	

ELECTRICAL-IGNITION SYSTEM

Coil	Make	Delco-Remy	
	Model	1115091	
	Amps	Engine stopped	4
Engine idling		1.8	
Distributor	Make	Delco-Remy	
	Model	1110890 (b)	
	Spark adv. (centrifugal; crankshaft points @ rpm degrees)	Start (rpm)	0° @ 600 (c)
		Intermediate	14° @ 1500 (c)
		Max. @ rpm	28° @ 3700 (c)
	Spark adv. vacuum (crankshaft points, deg. @ rpm degrees)	Start (in. Hg)	0° @ 8" Hg. (d)
		Intermediate	N.A.
		Max. @ in. Hg.	15° @ 15.5" Hg. (d)
	Breaker gap (in.)	.018	
	Cam angle (deg.)	29	
Breaker arm tension (oz.)	19-23		
Crankshaft deg. @ rpm.	4° BTDC @ 600 RPM. (a)		
Timing	Mark location	Damper	
	Cylinder numbering system (see page 2)	Left Bank 1-3-5-7; Right Bank 2,4,6,8	
	Firing order (see page 2)	1-8-4-3-6-5-7-2	
Spark Plug	Make and model	AC 46	
	Thread (mm)	14	
	Tightening torque (lb. ft.)	20-25	
	Gap	.035	
Cable	Conductor type	Linen Core Impregnated With An Electrical Conducting Material	
	Insulation type	Rubber With Neoprene Jacket	
	Spark plug protector	Eypalon Jacket	

ELECTRICAL-SUPPRESSION

Description Non-Metallic High Tension Cable

- (a) - Fuel Injection With Special Camshaft 14° BTC @ 1000 RPM. Rev. Form 6-57
- (b) - 1110891 With Two 4-Barrel Carburetors; 1110915 With Fuel Injection, Regular Camshaft; 1110914 With Fuel Injection And Special Camshaft.
- (c) - 0° At 1000 RPM, 5° At 1500, 22° At 6000 With Fuel Injection Special Camshaft.
- (d) - 0° At 5", 24° At 13.5" With Fuel Injection; No Vac. Adv. With 2 x 4 or Fuel Injection With Special Camshaft.

AMA Specifications - Passenger Car

MAKE OF CAR CHEVROLET MODEL YEAR 1958 DATE ISSUED 8-27-57 REVISED 10-31-57

MODEL CORVETTE

ELECTRICAL--INSTRUMENTS AND SWITCHES

Speed-ometer	Make	AC	
	Trip odometer (yes, no)	NO	
Charge indicator-type		AMMETER	← EC
Temperature indicator-type		ELECTRIC	
Oil pressure indicator-type		BOURDON TUBE	
Fuel indicator-type		ELECTRIC	
Other:			
Ignition switch	Identify positions in order and circuits controlled	VERTICAL	OFF, UNLOCKED
		COUNTER CLOCKWISE	OFF, LOCKED
		1ST POS. CLOCKWISE FROM VERTICAL	IGNITION & ACCESSORIES ON
	2ND POS. CLOCKWISE FROM VERTICAL	IGNITION & STARTER ON WITH SPRING RETURN TO 1ST POS.	
	Provision for illumination:	YES	
	Location	ON INSTRUMENT PANEL - RIGHT OF STEERING COLUMN	
Main lighting switch	Identify positions and lights controlled	DEPRESSED - OFF	
		1ST NOTCH - INSTR. PANEL LIGHTS, PARKING LIGHTS 2ND NOTCH - INSTR. PANEL LIGHTS, DRIVING LIGHTS ROTATE CLOCKWISE TO DIM AND TURN OFF INSTR. PANEL LIGHTS; COUNTER CLOCKWISE TO TURN ON AND BRIGHTEN PANEL LIGHTS	
Other light switches	Locations and lamps controlled	TOE PANEL	HEADLIGHT DIMMER
		STEERING COLUMN	TURN SIGNAL LAMPS
		HINGE PILLAR	COURTESY LAMP
		ON BRACE BELOW INSTR.	STOP LAMP
		PARKING BRAKE LEVER HOUSING	PARKING BRAKE ALARM LAMP
Other switches	Locations and devices controlled	INSTRUMENT PANEL	FOLDING TOP
		INSTRUMENT PANEL	ELEC. WINDSHIELD WIPERS
		L.E. & R.H. DOOR	ELEC. WINDOW LIFTS
		INSTRUMENT LOWER PANEL	RADIO ON-OFF SWITCH
		INSTRUMENT LOWER PANEL	HEATER & BLOWER SWITCH
Windshield wiper	Make	DELCO (MOTOR UNIT TRICO)	
	Type	ELECTRIC	
	Vacuum booster provision	NONE	
	Washer provision	DEALER INSTALLED ACCESSORY (a)	
Horn	Type	VIBRATOR	
	Number used	2	
	Amp draw (each)	HIGH 9, LOW 10	

(a) - INCLUDES CO-ORDINATOR AND VACUUM RESERVE TANK.

FA
TC
G

AMA Specifications -- Passenger Car

MAKE OF CAR CHEVROLET MODEL YEAR 1958 DATE ISSUED 8-27-57 REVISED 10-31-57

MODEL CODES: _____

ELECTRICAL--LAMP BULBS

Give quantity used and trade number, e.g., Headlamp 2-5400 5, dual headlight 2-4001, 2-4002. Indicate accessories which are not standard equipment by an asterisk following the numbers.

Headlamps & arrangement		DUAL-HORIZONTAL 2-4001, 2-4002
Headlamp beam indicator		1-53
Parking light		2-1034
Tail light		2-1034
Stop light		SEE TAIL LIGHT.
Direction signal	Front	SEE PARKING LIGHT
	Rear	SEE TAIL LIGHT
	Indicator	2-53
License plate light		2-67
Instrument light		4-57
Ignition lock light		1-53
Back up light		NONE
Dome light		NONE
Clock light		1-57
Radio light		1-GE 1891*
Glove compartment light		NONE
COURTESY LIGHT		2-90*
CIGARETTE LIGHTER LIGHT		1-53
PARKING BRAKE ALARM LIGHT		1-90*

ELECTRICAL--FUSE & CIRCUIT BREAKER DATA

Use trade number of fuse, e.g., SFE-10. Indicate circuit breaker by ampere capacity suffixed by letters "C.B.," e.g., 30 C.B. Where fuse or circuit breaker protects multiple circuits indicate first use by a letter and repeat the same letter for all units protected by the same fuse or circuit breaker, e.g., Parking lights SFE-10 (a), Direction indicator same as (a).

Headlamp	13 CB (a)
Headlamp beam indicator	Same as (a)
Parking light	Same as (a)
Tail light	Same as (a)
Stop light	Same as (a)
Direction indicator	Same as (a)
License plate light	Same as (a) and (1) AGA 3 Amp. Fuse
Instrument light	Same as (a) and (1) AGA 3 Amp. Fuse
Ignition light	Same as (a)
Back up light	None
Dome light	None
Clock	Same as (a)
Clock light	Same as (a)
Radio	AGW 7-1/2 Fuse
Glove compartment light	None
HEATER	SFE 14 Fuse

AMA Specifications - Passenger Car

MAKE OF CAR CHEVROLET MODEL YEAR 1958 DATE ISSUED 8-27-57 REVISED 10-31-57

MODEL CORVETTE

DRIVE UNITS—CLUTCH (Manual Transmission)

Make & type	BORG & BECK, DRY PLATE	
Type pressure plate springs	COIL	
Total plate pressure (lb.)	1620 INITIAL	
No. of clutch driven discs	ONE	
Clutch facing	Material	PREMIUM WOVEN ASBESTOS COMP.
	Outside & inside dia.	10.0 X 6.5
	Total eff. area (sq.in.)	90.72
	Thickness	.132-.138
	Engagement cushioning method	SPRINGS
Release bearing	Type & method of lubrication	BALL BEARING, SEALED
Torsional damping	Methods: springs, friction material	SPRING AT HUB

DRIVE UNITS—TRANSMISSIONS

Manual (std. or opt.)	3-SPEED CLOSE RATIO (4-SPEED OPTIONAL)
Manual with overdrive (std. or opt.)	NONE
Automatic (std. or opt.)	OPTIONAL

DRIVE UNITS—MANUAL TRANSMISSION

Number of forward speeds		3-SPEED CLOSE RATIO	OPTIONAL 4-SPEED, 4	
Transmission ratios	In first	2.21:1	2.20:1	
	In second	1.32:1	1.66:1	
	In third	1.00:1	1.31:1	
	In fourth	NONE	1.00:1	
	In reverse	2.21:1	2.25:1	
Synchronous meshing, specify gears		2ND & 3RD	1ST, 2ND, 3RD, 4TH.	
Lubricant	Capacity (pt.)	2	1-1/2	
	Type recommended	A-9 MINERAL OIL LUBRICANT		
	SAE viscosity number	Summer	SAE 90	
		Winter	SAE 90	
Extreme cold		SAE 80		

AMA Specifications - Passenger Car

MAKE OF CAR CHEVROLET MODEL YEAR 1958 DATE ISSUED 8-27-57 REVISED 10-31-
 MODEL CORVETTE

DRIVE UNITS—MANUAL TRANSMISSION WITH OVERDRIVE

For transmission data see manual transmission section

Overdrive	Type (planetary or other)		NONE	
	Manual lockout (yes, no)		-	
	Downshift accelerator control (yes, no)		-	
	Minimum cut-in speed		-	
	Gear ratio		-	
	Lu- bri- cant	Capacity (Overdrive only)		-
		Separate filler (yes, no)		-
		Type recommended		-
		SAE vis- cosity number	Summer	-
			Winter	-
Ext. cold		-		

DRIVE UNITS—AUTOMATIC TRANSMISSION

Trade name		POWERGLIDE	
Type describe		TORQUE CONVERTER WITH PLANETARY GEARS	
Method of Selection (Lever, Push Button or other)		LEVER	
Selector Pattern		P-PARK R-REVERSE N-NEUTRAL D-DRIVE L-LOW	
List gear ratios Selector Pattern and indicate which are used in each selector position		DRIVE 1.82:1 LOW 1.82:1 REVERSE 1.82:1	
Max. upshift speeds—drive range		55 MPH	
Max. kickdown speeds—drive range		50 MPH	
Torque converter	Number of elements		3
	Max. ratio at stall at engine rpm		2.1:1
	Type of cooling (air, water)		AIR
Lubricant	Capacity—refill (pt.)		CAPACITY, 22 PINTS; REFILL, 9 PINTS
	Type recommended		AUTOMATIC FLUID TYPE A
Special transmission features		3 ELEMENT HYDRAULIC TORQUE CONVERTER WITH AUTOMATIC PLANETARY GEAR SYSTEM FOR REVERSE AND LOW	

AMA Specifications - Passenger Car

MAKE OF CAR CHEVROLET MODEL YEAR 1958 DATE ISSUED 8-27-57 REVISED 10-31-57

MODEL CORVETTE

DRIVE UNITS—PROPELLED SHAFT

Number used		1
Type (exposed, torque tube)		EXPOSED HOTCHKISS
Outer diameter x length* x wall thickness	Manual transmission	2.370 X .065 (EFF. LENGTH VARIES DUE TO U-JOINT SLIP ON SPLINE)
	Overdrive transmission	NONE
	Automatic transmission	SAME AS MANUAL TRANSMISSION
Inter-mediate bearing	Type (plain, anti-friction)	NONE
	Lubrication (fitting, prepack)	NONE
Universal joints	Make	OWN
	Number used	2
	Type (ball and trunnion, cross, other)	YOKE AND SPIDER (TRUNNION)
	Bearing	Type (plain, anti-friction)
Lubric. (fitting, prepack)		2 FITTINGS
Drive taken through (torque tube or arms, springs)		REAR SPRINGS
Torque taken through (torque tube or arms, springs)		REAR SPRINGS

DRIVE UNITS—REAR AXLE

Description - (incl. limited slip differential)		HYPOID, SEMI-FLOATING	
Drive Pinion Offset		1.5	
No. of differential pinions		TWO	
Gear ratio and No. of teeth	Automatic transmission	3.55:1 (9-32) :-(9-32)	
	Overdrive trans.	NONE	
	Manual transmission	3.70:1(10-37) 3-SPEED CLOSE RATIO STD. (A)	
Ring gear pitch diameter & O.D.		8.375	
Pinion adjustment (shim, other)		SHIM	
Pinion bearing adj. (shim, other)		NONE	
Wheel bearing type		BALL	
Lubricant	Capacity (pt.)	4	
	Type recommended	SAE 90 HYPOID LUBRICANT	
	SAE viscosity number	Summer	SAE 90
		Winter	SAE 90
Extreme cold		SAE 90	

*Center to center of universal joints, or to centerline of rear attachment.

(A) 4.11:1 (9-37), 4.56:1 (9-41) OPTIONAL

AMA Specifications – Passenger Car

MAKE OF CAR CHEVROLET MODEL YEAR 1958 DATE ISSUED 8-27-57 REVISED 10-31-57

MODEL CORVETTE

DRIVE UNITS—WHEELS

Type & material	SHORT SPOKE DISC, PRESSED STEEL
Rim (size and flange type)	15 X 5K
Attachment: Type (bolt or stud)	STUD
Circle diameter	4-3/4
Number and size	5, 7/16-20

DRIVE UNITS—TIRES

Size (L-102): Standard	6.70-15-4 PLY TUBELESS
& ply rating: Optional	6.70-15-4 PLY WHITE & BACKWALL
Type tires - nylon, etc.	RAYON CORD
Rev/mile at 30 mph	755
Inflation: Front	24 LB.
press.(cold): Rear	24 LB.

BRAKES—SERVICE

Type	SERVO-4 WHEEL HYDRAULIC (HEAVY DUTY, OPTIONAL) (a)			
Power brake type	NOT AVAILABLE			
Effective area (sq. in.)	157 (121 WITH HD BRAKE OPTION)			
Percent brake effectiveness-front	56% (38% WITH HD BRAKE OPTION)			
Drum	Diameter	Front	11	
		Rear	11	
	Type and material	COMPOSITE; RIM, CAST ALLOY IRON; WEB, PRESSED STEEL (b)		
	Bonded or riveted	BONDED (WELDED TO THE SHOE WHEN HD BRAKE OPTION IS USED)		
Brake lining	Material	FULL MOLDED ASBESTOS COMPOSITION (c)		
		Size (length x width x thickness)	Front wheel	9.29 X 2.0 X .175 (d)
		Rear wheel	9.29 X 1.75 X .175 (e)	
	Segments per shoe	ONE		
Rear Shoe	Material	FULL MOLDED ASBESTOS COMPOSITION (c)		
		Size (length x width x thickness)	Front wheel	11.69 X 2.0 X .175 (f)
		Rear wheel	11.69 X 1.75 X .175 (g)	
	Segments per shoe	ONE		
Wheel cylinder bore	Front	1.125		
	Rear	1.0 (.875 WITH HD BRAKE OPTION)		
Master cylinder bore	1.0			
Available pedal travel	4.50			
Line pressure at 100 lb. pedal load	700 APPROX.			
Shoe clearance adjustment	ADJUST TO LIGHT DRAG & BACK OFF 7 NOTCHES			

Rev. Form 6-57

- (a) OPTIONAL HEAVY DUTY BRAKES AVAILABLE WITH OR WITHOUT AIR INTAKE BUCTS FOR AIR COOLED BRAKES
- (b) DRUMS, WITH COOLING VANES CAST ON RIM, USED WITH HD. BRAKE OPTION
- (c) SINTERED METAL & CERAMIC WITH HD BRAKE OPTION
- (d) 2-PIECE, 2.24 X 2.50 X .185 WITH HD BRAKE OPTION
- (e) 2-PIECE, 2.24 X 2.00 X .185 WITH HD BRAKE OPTION
- (f) 4-PIECE, 2.24 X 2.50 X .185 WITH HD BRAKE OPTION
- (g) 4-PIECE, 2.24 X 2.00 X .185 WITH HD BRAKE OPTION

AMA Specifications - Passenger Car

MAKE OF CAR CHEVROLET MODEL YEAR 1958 DATE ISSUED 8-27-57 REVISED 10-31-57

MODEL CORVETTE

BRAKES—PARKING

Type of control		T-HANDLE PULL ROD
Location of control		L.H. SIDE OF STEERING COLUMN, BELOW INST. PANEL
Operates on		REAR SERVICE BRAKES
If separate from service brakes	Type (internal or external)	NONE
	Drum diameter	NONE
	Lining size (length x width x thickness)	NONE

FRAME or UNITIZED CONSTRUCTION

Type and description	FULL LENGTH, WELDED, BOX SECTION SIDE AND CROSS MEMBERS "I" BEAM TYPE, BRACING FROM "X" MEMBER TO FRAME FRONT SIDE MEMBER. REAR SHOCK ABSORBER CROSS MEMBER OF "U" TYPE "I" BEAM TYPE "X" MEMBER.
----------------------	---

SUSPENSION—GENERAL

Provision for car leveling		NONE
Provision for brake dip control		NONE
Provision for acc. squat control		NONE
Special provisions for car jacking		NONE
Shock absorber front & rear	Type	DIRECT, DOUBLE ACTING
	Make	DELCO
	Piston dia.	1.0 (a)
Other special features		

SUSPENSION—FRONT

Type and description	UNITIZED, INDEPENDENT, SHORT & LONG ARM
----------------------	---

(Continued)

Rev. Form 6-57

(a) - 1-3/8 DIA. ON OPTIONAL HEAVY DUTY SUSPENSION.

AMA Specifications - Passenger Car

MAKE OF CAR CHEVROLET MODEL YEAR 1958 DATE ISSUED 8-27-57 REVISED 10-31-57

MODEL CORVETTE

SUSPENSION FRONT (cont.)

Spring	Type	COIL
	Material	CHROME ALLOY STEEL
	Size (coil design height & I.D.; bar length x dia.)	13.45 FREE HEIGHT X 3.162 (a)
	Spring rate (lb. per in.)	300 (340 WITH OPTIONAL HD FRONT SPRINGS (a))
	Rate at wheel (lb. per in.)	110
Stabilizer	Design load (lb. @ design height)	1145 @ 9.62
	Type (link, linkless, frameless)	LINK (a)
	Material & bar diameter	11/16 (13/16 ON HEAVY DUTY SUSPENSION)

STEERING

Mechanical (std., opt., NA)		STANDARD
Power (std., opt., NA)		NA
Wheel diameter		17.25
Turning diameter	Outside front	38-1/2 FT. RIGHT - 39 FT. LEFT
	Wall to wall (l. & r.)	36-1/2 FT. RIGHT - 37 FT. LEFT
	Curb to curb (l. & r.)	NA
	Inside rear	NA
Wall to wall (l. & r.)		NA
Curb to curb (l. & r.)		NA
Outside wheel angle with inside wheel at 20°		23°

Mechanical	Gear	Type	SEMI-REVERSIBLE RECIRCULATING BALL	
		Make	SAGINAW	
		Ratio	Gear	21.0:1
	Overall	21.0:1 (16.3:1 OPTIONAL)		
	No. wheel turns		3.7 LOCK TO LOCK	

Power	Type	NONE		
	Make	NONE		
	Trade name	NONE		
	Gear	Type	-	
		Ratio	Gear	-
		Overall	-	
	Pump driven by		-	
	Overall torque ratio		-	
	Number wheel turns		-	

Linkage	Type	CENTER POINT
	Location (front or rear of wheels, other)	REAR OF WHEELS
	Drag link (trans. or longit.)	LONGITUDINAL
	Tie rods (one or two)	TWO

(Continued)

Rev. Form 6-57

(a) - HEAVY DUTY SUSPENSION, INCLUDES HD FRONT & REAR SPRINGS, SHOCK ABSORBERS, STABILIZER, & QUICK STEERING ADAPTER.

AMA Specifications - Passenger Car

MAKE OF CAR CHEVROLET MODEL YEAR 1958 DATE ISSUED 8-27-57 REVISED 10-31-57

MODEL CORVETTE

STEERING (cont.)

Steering Axis	Inclination of camber (deg.)		3°30' - 4°30'
	Bearings (type)	Upper	RUSHING
		Lower	RUSHING
		Thrust	SINGLE ROW BALL
Wheel alignment (range and preferred)	Caster (deg.)		2°10' - 2°15'
	Camber (deg.)		0-1°
	Toe-in (outside tread-inches)		0-.125
	Steering spindle & joint type		REVERSE ELLIOTT
Wheel spindle	Diameter	Inner bearing	1.2810-1.2815
		Outer bearing	.7498-.7503
	Thread size		3/4-20
	Bearing type		BALL

SUSPENSION-REAR

Type and description			OUTRIGGER MOUNTED SEMI-ELLIPTIC LEAF SPRINGS	
Drive and torq. taken through (see page 14)			REAR SPRINGS	
Spring	Type		SEMI-ELLIPTIC	
	Material		ALLOY STEEL	
	Size (length x width, coil design height and I.D.; bar length & dia.)		51.0 X 2.0 X 4	
	Spring rate (lb. per in.)		115 (125 WITH OPTIONAL HD REAR SPRINGS) (a)	
	Rate at wheel (lb. per in.)		NA	
	Design load (lb. at design height)		725	
	Mounting insulation type		RUBBER BUSHED	
	If leaf	No. of leaves		4
		Inserts	Type and size	3 LINERS: 19.8 X 1.9 X .10; 31.8 X 1.9 X .10; 46.3 X 1.9X
			Material	WAX IMPREGNATED FIBRE BOARD
Shackle (comp. or tens.)		IN TENSION FROM REAR HANGER		
Stabilizer	Type (link, linkless, frameless)		NONE	
	Material		NONE	
Track bar type			NONE	

(a) - HEAVY DUTY SUSPENSION OPTIONAL.

AMA Specifications - Passenger Car

Page 19

MAKE OF CAR Chevrolet MODEL YEAR 1958 DATE ISSUED 8-27-57 REVISED 10-31-57

BODY-GENERAL DEFINITIONS

NOTE: Included in the dimension definitions listed on this and the following pages are those which have been adopted by the S.A.E. These are indicated by a number following the type of dimension, e.g. L 3. Additional dimensions have been added by the AMA Specifications Body Sub-Committee for inclusion in the Questionnaire. These are shown by an additional letter, e.g., MA. Symbol "a" added as suffix to SAE dimensions indicates an AMA modification. The dimensions are developed from the following basic points:

1. Front and rear seat free "A" points are taken 5" forward of vertical tangent to seat back 15" from center of body.
2. Front and rear seat "B" points are located on seat back 15" from center of body at height of horizontal tangent to top of seat cushion.
3. Front seat is in the full down and normal rearmost position.
4. Loaded position—5 passenger, front 300 lb., rear 450 lb.; includes spare wheel, tire and tools, and full complement of gas, oil, water, and tires to recommended pressure, etc.
5. C/L (centerline).
6. D. L. O. (daylight opening, exposed glass dimension - pages 21, 23 & 25).
7. Ramp breakover angle (page 21) is the supplement of the included ramp angle (180° minus the included ramp angle) over which a car can pass without hanging up.

MODEL Corvette

BODY-TRUNK DIMENSIONS

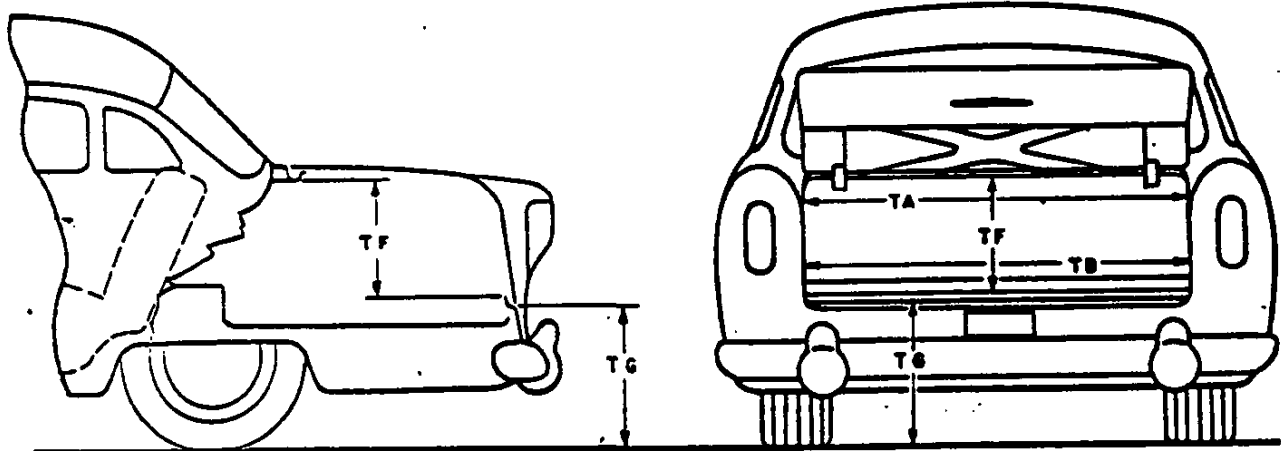

Usable trunk luggage capacity (see Section H1 of SAE Automotive Drafting Standards)	N.A.
TA—Width across the top	45.0
TB—Width across the bottom	40.0
TF—Vertical dimension at C/L from bottom to top of opening.	14.2
TG—Vertical height from ground to trunk lower opening (normal surface of outside sheet metal - loaded)	N.A.
Position of spare tire stowage	Horizontal In Trunk Under Floor
Method of holding lid open	Counterbalance Springs

Rev. Form 6-57

TRUNK

AMA Specifications -- Passenger Car

MAKE OF CAR Chevrolet MODEL YEAR 1958 DATE ISSUED 8-27-57 REVISED 10-31-57

MODEL Corvette

BODY--HEIGHT DIMENSIONS--INTERIOR

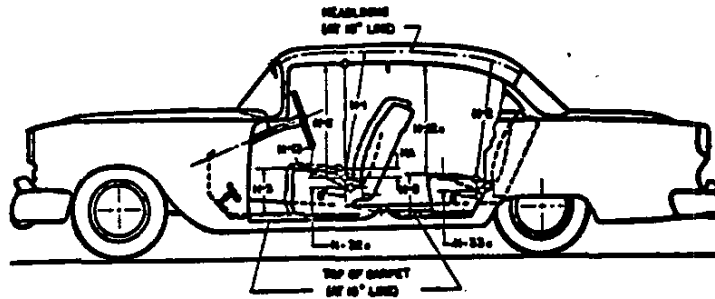

H1. Front headroom—from free "A" pt. to headlining at 8° back of vertical on 15" line. (For "A" pt. see note 1, page 19)	34.7 *
H2. Rear headroom—from free "A" pt. to headlining at 8° back of vertical on 15" line.	—
H3. Front cushion height above low point on floor carpet on 15" line (front edge of cushion).	8.9
H8. Rear cushion height above low point on floor carpet on 15" line (front edge of cushion).	—
H11. Entrance—front—cushion free "A" point to bottom windcard vertical.	28.4
H12a. Entrance — rear — top of cushion at vertical tangent to front of rear seat, to bottom of windcard in rear.	—
H13. Steering wheel clearance to seat cushion taken on arc (wheel turned for min. clearance).	4.9
HA. Front seat maximum vertical rise at free "A" point.	N.A.
HF. Front seat maximum vertical rise of free "A" point with multiple-position seat.	N.A.
H32a. Front seat depressed depth — vertical dimension from free "A" point to depressed "A" point.	2.0
H33a. Rear seat depressed depth — vertical dimension from free "A" point to depressed "A" point.	—

→ - 34.5 For Optional Hardtop.

AMA Specifications – Passenger Car

MAKE OF CAR Chevrolet MODEL YEAR 1958 DATE ISSUED 8-27-57 REVISED 10-31-57

MODEL Corvette

BODY—HEIGHT DIMENSIONS—EXTERIOR

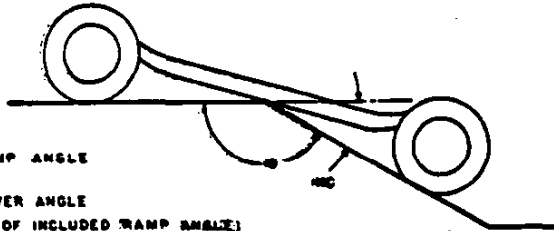
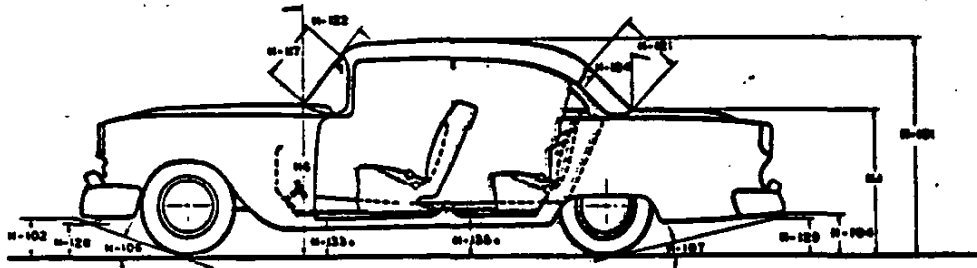

H101. Overall height - loaded.	51.1 Top Up (a)
H8. Overall height - curb weight.	52.0 Top Up (b)
H102. Front bumper bottom to ground at normal section.	16.9
H104. Rear bumper bottom to ground at normal section.	14.1
H106. Angle of appr.-fr. tire static loaded rad. to interfering pt. on fr. bumper, gd., other.	20.0
H107. Angle of dep.-fr. tire static loaded rad. to interfering pt. on rr. bumper, gd., other.	14.4
HC. Ramp breakover angle.*	14.5
H117. Windshield DLO-slant height.	17.3
H121. Backlight DLO*-max., slant height.	11.5
H122. Windshield slope angle to vertical line on car axis.	50°
H124. Backlight slope angle to vertical line on car axis.	N.A.
H128. Ground to bottom of front bumper guard.	9.0
H129. Ground to bottom of rear bumper guard.	7.7
H133a. Bottom of front door to ground, min. dimension - car loaded.	N.A.
H133b. Bottom of rear door to ground, min. dimension - car loaded.	—
HD. Min. road clear. (5 pass. load) & loc.	5.8 Rear Spring Front Hanger
HE. Min. road clearance at rear axle.	8.0
HG. Hood at rr. to grd.-vert. dim. excl. molding, fr. hood opening line at cowl (curb wt.)	35.4
HH. Max. ht., fr. grd. frt. of windshield (curb wt.)	N.A.
HJ. Max. ht., fr. grd. back of r. window (curb wt.)	N.A.

* See Notes, page 19. (a) - 51.0 Optional Hardtop.
 (b) - 52.0 Optional Hardtop.

AMA Specifications - Passenger Car

MAKE OF CAR Chevrolet MODEL YEAR 1958 DATE ISSUED 8-27-57 REVISED 10-31-57
 MODEL Corvette

BODY-LENGTH DIMENSIONS

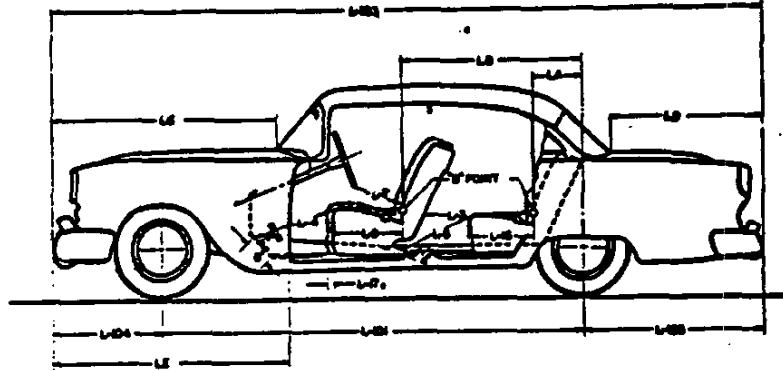

Interior	L13. Rear compartment of front seat back to rear seat back.	--
	L14. Leg room—front—ball of foot to top of seat to seat back—15" line.	44.2
	L15. Leg room—rear—from ball of foot to top of seat cushion and to seat back†	--
	L17. Steering wheel clearance to seat back taken on arc.	14.6
	L19. Front seat depth (front edge to vert. tan. to seat back on 15" line).	18.2
	L16. Depth of rear seat (front edge to seat back).	--
	L17a. Total adjustment of front seat at front lower seat frame.	4.4
	LA. Rear seat "B" point to center line of rear axle.	--
	LB. Front seat "B" point to center line of rear axle.	N.A.
	LC. Front of car to base of windshield.	N.A.
	LD. Rear of car to base of rear window or upper structure.	N.A.
	LE. Front of car to front edge of front door.	N.A.
Exterior	L101. Wheelbase.	102
	L103. Overall length (bumper to bumper inc. guards).	177.2
	L104. Overhang—front including bumper guards.	33.0
	L105. Overhang—rear including bumper guards.	42.2

* Dimension taken on 15" line—see notes 1 & 2, page 19.

AMA Specifications - Passenger Car

MAKE OF CAR Chevrolet MODEL YEAR 1958 DATE ISSUED 8-27-57 REVISED 10-31-57

MODEL Corvette

BODY-WIDTH DIMENSIONS

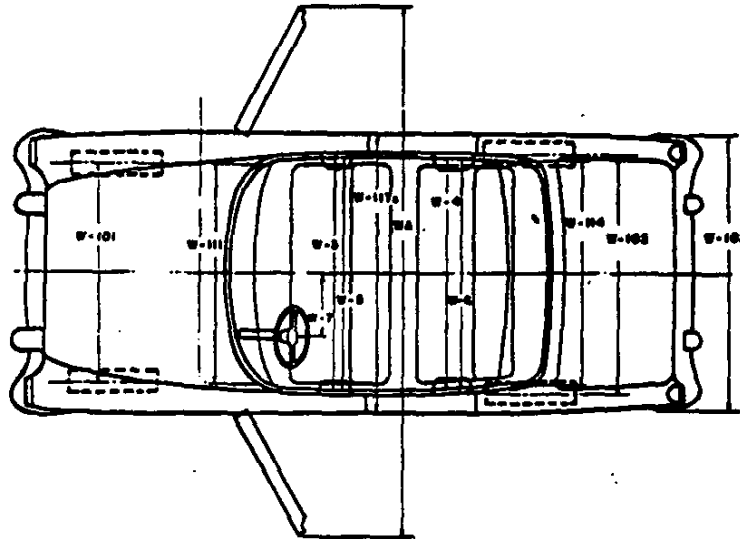

Interior	W3. Front shoulder room, at garnish moulding height or nearest interference 5" forward of seat back.	49.4
	W4. Rear shoulder room, at garnish moulding height or nearest interference 5" forward of seat back.	--
	W5. Front hip room, at top of seat 5" forward of vert. tan. to seat back.	49.1
	W6. Rear hip room, at top of seat 5" forward of vert. tan. to seat back.	--
	W7. Steering wheel center to center of body.	N.A.
Exterior	W101. Front tread at ground.	57.0
	W102. Rear tread at ground.	59.0
	W103. Max. overall width of car including bumpers or moldings.	72.8
	W104. Max. overall width of car with doors open.	N.A.
	W111. Windshield DLO, max. width.	53.6
	W114. Back window DLO, max. width.	34.3
	W117a. Max. body width at center pillar, less hardware and applied moldings.	70.3

AMA Specifications – Passenger Car

MAKE OF CAR Chevrolet MODEL YEAR 1958 DATE ISSUED 8-27-57 REVISED 10-31-57
 MODEL Corvette

STATION WAGON—CARGO SPACE DIMENSIONS

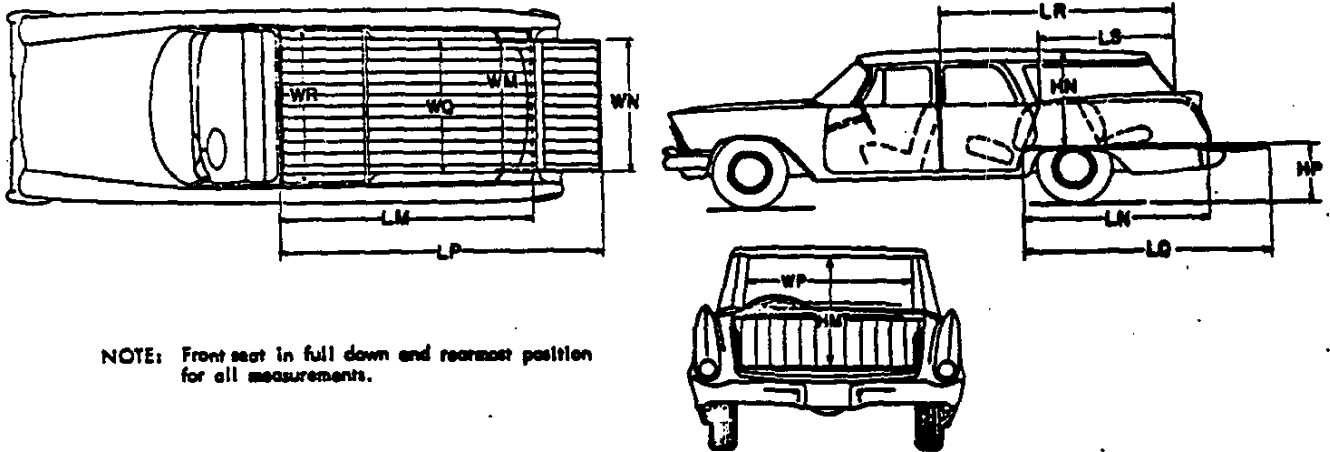

NOTE: Front seat in full down and rearmost position for all measurements.

LM Floor length from bottom of front seat to inside of tail gate in raised position.	Not Applicable
LN Floor lgth. from bottom of second seat to inside of tail gate in raised position.	"
LP Floor lgth. from bottom of front seat to end of tail gate in lowered position.	"
LQ Floor lgth. from bottom of second seat to end of tail gate - tail gate lowered.	"
HM Maximum hgth. of rear opening - tail gate lowered.	"
WM Rear end opening width at floor.	"
WN Rear end opening width at top of tail gate.	"
WQ Minimum distance between wheelhouses.	"
WP Maximum width of rear opening above raised tail gate.	"
WR Maximum width of cargo space at floor.	"
LR Cargo horizontal distance from top rear of front seat back to top of tail gate.	"
LS Cargo horizontal distance from top rear of second seat back to top of tail gate.	"
MN Maximum height of roof above floor at center line of car.	"
MP Platform height at end of lowered tail gate - curb weight.	"
Third Seat - facing direction.	"

AMA Specifications - Passenger Car

MAKE OF CAR Chevrolet MODEL YEAR 1958 DATE ISSUED 8-27-57 REVISED 10-31-57

MODEL Corvette

BODY-MISCELLANEOUS INFORMATION

Drs. hinged (front, rear)	Front
Front doors	
Rear doors	--
Type of finish (lacquer, enamel).	Lacquer
Hood hinge location (front, rear).	Front
Hood counterbalanced (yes, no).	No
Hood release control (internal, external).	Internal
Vehicle (Serial) No. Location	On Plate Attached To Left Front Body Hinge Piller
Engine No. location	On Plate Attached To Left Front Body Hinge Piller
Theft protection - type	Ignition Switch-Key Can Not Be Removed In Off (Unlocked) Position
Vent window control method (crank, friction pivot).	Pivot
Windshield type (single curved, compound curved, other)	Single Curved
Rear window type (flat, curved, one piece, three piece)	Standard Folding Top, One Piece Flat Plastic Optional Plastic Hardtop, One Piece Curved Glass
Side glass type (curved, flat)	Flat
Windshield glass area D.I.C.	908 Sq. In.
Backlight glass area D.I.C.	402 Sq. In.
Total glass area D.I.C.	1816 Sq. In.

BODY-TYPES AND STYLE NAMES

Body type, number of passengers & style names; use manufacturer's code for series & body style.

BODY STYLES:

CODES

Corvette

667

2-Door Convertible 2-Passenger

AMA Specifications -- Passenger Car

MAKE OF CAR Chevrolet MODEL YEAR 1958 DATE ISSUED 8-27-57 REVISED 2-28-58

SUPPLEMENTARY INFORMATION

MAJOR OPTIONAL ITEMS - WEIGHTS

Model	CURB - WEIGHT - POUNDS			SHIPPING WEIGHT
	Front	Rear	Total	
1121 Utility Sedan	1819	1645	3464	3308
1141 2-Door Sedan	1819	1864	3503	3347
1149 4-Door Sedan	1847	1721	3562	3406
1171 Sedan Del.	1763	1772	3535	3396
1191 2-Dr. Sta. Wagon	1813	1996	3809	3670
1193 4-Dr. Sta. Wagon	1806	2054	3860	3721
1541 2-Door Sedan	1825	1689	3514	3358
1549 4-Door Sedan	1850	1737	3587	3431
1593 4-Dr. Sta. Wagon	1817	2055	3872	3733
1594 4-Dr. Sta. Wagon	1823	2079	3902	3763
1731 2-Dr. Spt. Coupe	1853	1680	3533	3377
1739 4-Dr. Spt. Sedan	1876	1757	3633	3477
1741 2-Door Sedan	1849	1668	3517	3361
1747 Spec. Sport Coupe	1859	1716	3575	3419
1749 4-Door Sedan	1868	1721	3589	3433
1767 Convertible	1885	1753	3638	3482
1793 4-Dr. Sta. Wagon	1831	2040	3871	3732
<hr/>				
Accessories & Equipment Weights				
Powerglide			+104	
Overdrive			+ 34	
Power Steering			+ 25	
Power Brakes			+ 11	
<hr/>				
<hr/>				
<hr/>				
<hr/>				
<hr/>				
<hr/>				
<hr/>				
<hr/>				
<hr/>				
<hr/>				
<hr/>				
<hr/>				
<hr/>				
<hr/>				
Gross Weight	1 Front	450 (A)	450 (B)	XXXXXXXXXXXXXXXXXXXX
	2 Rear			XXXXXXXXXXXXXXXXXXXX

(A) - 1171:150
 (B) - 1171-1121:000, 1594:900, 1747-1767:300

AMA Specifications -- Passenger Car

PAGE 27

INDEX

SUBJECT	PAGE NO.	SUBJECT	PAGE NO.
Air Suspension	16	Lamp Bulbs	11
Angles of Approach, Departure	21	Legroom	22
Automatic Transmission	1, 13	Lengths - Car, & Body Interior	1, 22
Axle, Rear	1, 14	Lifters, Valve	4
Battery	8	Linings - Clutch, Brake	12, 15
Bearings, Engine	3, 4, 7	Lubrication	5, 4, 12, 13, 14
Belts - Fan, Generator, Water Pump	7	Motor, Starting	8
Body - General Information, Types	19, 25	Muffler	6
Height Dimensions	21	Overdrive	13
Length Dimensions	22	Piston Pins & Rings	3
Overall Dimensions	1, 21, 22, 23	Pistons	2, 3
Trunk Capacities, Opening Dimensions	19	Power Brakes	15
Width Dimensions	23	Power Steering	17
Brakes - Parking, Service, Power	15, 16	Propeller Shaft, Universal Joints	14
Cambar	18	Pumps - Oil, Fuel	6
Camshaft	4	Water	7
Capacities		Radiator, Hoses	7
Cooling System	7	Ramp Break-over Angle	21
Fuel Tank	6	Ratios - Axle	1, 14
Lubricants		Compression	1, 2
Engine Crankcase	6	Steering	17
Transmission and Overdrive	12, 13	Transmission	12, 13
Rear Axle	15	Rear Axle	1, 14
Carburetor	6	Regulator - Generator	8
Caster	18	Rims	15
Choke, Automatic	6	Rings, Piston	3
Circuit Breakers, Fuses	11	Rods - Connecting	3
Clearance, Ground	21	Shock Absorbers, Front & Rear	14
Clutch - Pedal Operated	12	Spark Plugs	9
Coil, Ignition	9	Speedometer	10
Connecting Rods	3	Springs - Front & Rear Suspension	17, 18
Cooling System	7	Valve, Engine	5
Crankshaft	4	Stabilizer (Sway Bar) - Front & Rear	17, 18
Cylinders and Cylinder Head	2	Starting Motor	8
Distributor - Ignition	9	Steering	17, 18
Electrical System	8, 9, 10, 11	Suppression - Ignition, Radio	9
Engine		Suspension - Front & Rear	16, 17, 18
Bore, Stroke, Displacement, Type	1, 2	Switches	10
Compression Ratio	1, 2	Tailpipe	6
Firing Order, Cylinder Numbering	2, 9	Thermostat, Cooling	7
General Information, H.P. & Torque	1, 2	Timing, Engine & Valve	4, 5, 9
Lubrication	5, 6	Tires	1, 15
Exhaust System	6	Toe In	18
Fan, Cooling	7	Torque Converter	1, 2
Filters - Engine Oil, Fuel System	6	Torque - Engine, Rated	13
Frame	16	Transmission - Types	1, 12, 13
Front Suspension	16, 17	Automatic	1, 13
Fuel, Fuel Pump, Fuel System	6	Manual & Overdrive	12, 13
Fuel Injection	1, 6	Ratios	12, 13
Fuses, Circuit Breakers	11	Tread	1, 23
Generator and Regulator	8	Turning Diameter	17
Glass	21, 23, 25	Universal Joints, Propeller Shaft	14
Headroom - Body	20	Valves - Intake & Exhaust	4, 5
Heights - Car & Body	1, 20, 21	Vibration Damper	4
Head	25	Voltage Regulator	8
Horns	10	Water Pump	7
Horsepower - Brake, Rated, Taxable	1, 2	Weights - Shipping, Curb	26
Ignition System	9	Wheel Alignment	18
Inflation - Tires	15	Wheelbases	1, 22
Instruments	4, 10	Wheels & Tires	15
Kingpin	18	Wheel Spindle	18
		Widths - Car & Body	1, 22
		Windshield	21, 23, 24
		Windshield Wiper	11